



60 YEARS OF ITALIAN TRADITION

Luxor is an important industrial reality, world wide and European market leader in the production of flexible hoses and components for hydro and thermo-sanitary installations. Luxor has been the expression of the most prestigious made in Italy and the great Italian high technology mechanical workings tradition for fifty years; a quality certified and recognized by the most prestigious International Certification Institutes all over the world.

Our mission is the complete customer satisfaction through a process of continuous technological research in order to make high quality, reliable products, anticipating the market evolutions by innovative partnership with both customers and suppliers. Luxor mission takes

place in its own Research and Development Centre in which new and advanced technologies are constantly analyzed and researched with continuous investments to offer the most innovative and reliable solutions for the international markets at competitive costs, ensuring strict quality controls on each single piece.

Luxor entirely plans and realizes each product, thanks to its decennial know how. The great production strength, a "slender" innovative and advanced industrial organization together with a modern logistic conception, make Luxor able to satisfy every kind of request, even customized, with fast deliveries all over the world.



Luxor is certified ISO 9001:2015 by DEKRA Group certification body

CERTIFICATION



Please contact our offices for information about technical specifications and certified products or visit the website of the corresponding certification body for the latter.

Please refer to www.nsf.org for a complete list of NSF approved products.
Please refer to www.iapmort.org for a complete list of UPC/CUPC approved products.



LUXOR®

7 / FITTINGS

FITTINGS

COMPRESSION FITTINGS FOR COPPER, PLASTIC AND MULTILAYER PIPES



TECHNICAL DATA



Max temperature

120 °C



Max pressure

10 bar



Nuts

CW617N
UNI EN
12165:2016

Fittings

CW614N
UNI EN
12164:2016

Gaskets OR

EPDM



Gaskets

Polyethylene

SYSTEM CONNECTIONS



Iron pipe

W 24x19 - TR 91
G 3/4 EK - TR 91/A
G 1/2 - TR 890
G 1/2 - TR 94
G 1/2 - TR 92

Copper pipe

W 24x19 - TR 91
G 3/4 EK - TR 91/A
G 1/2 - TR 890
G 1/2 - TR 94
G 1/2 - TR 92

Plastic pipe

W 24x19 - TP 95
G 3/4 EK - TP 98
G 1/2 - TP 93

Multilayer pipe

W 24x19 - TP 97
G 3/4 EK - TP 99
G 1/2 - TP 96
G 1/2 F - TP 90

OPERATING INSTRUCTIONS

To avoid inconveniences caused by an improper installation, which could be very costly, it is advisable to follow the below instructions:

• How to prepare the pipe.

1. **Cutting the pipe.** For a correct cut, use suitable shears so as to avoid the ovalization of the pipe and take care that the cut is perpendicular to the pipe axis.

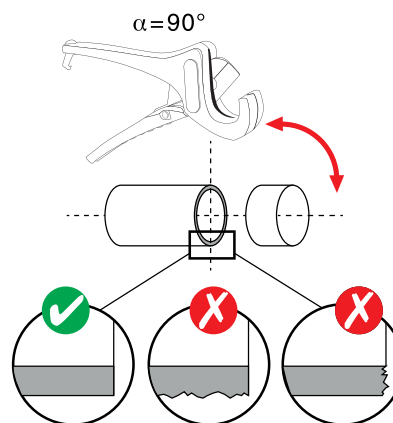

The characteristics of the fluid in the system must be compliant with the UNI 8065: 2019 directive.

2. Calibration. This operation guarantees to obtain a correct internal diameter.

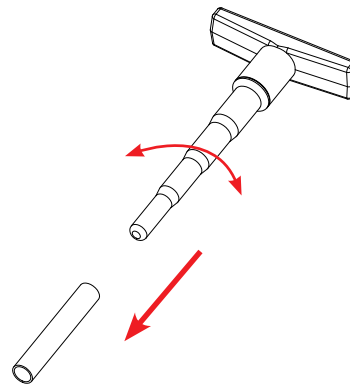

3. Flaring. This operation creates an internal chamfer which eases the insertion of the fitting in the pipe and avoids the displacement of the o-rings from their seat.

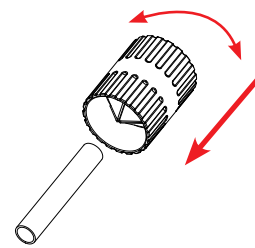

CORRECT ASSEMBLY OF THE COMPRESSION FITTING.

Assemble the parts of the fitting in the same order and direction shown in the below pictures.

FITTINGS FOR COPPER PIPE/MILD STEEL			FITTINGS FOR PLASTIC PIPE	FITTINGS FOR MULTILAYER PIPE
TR 91 • TR 91/A	TR 92	TR 94	TP 93 • TP 95 • TP 98	TP 96 • TP 97 • TP 99
↓	↓	↓	↓	↓

Insert the pipe with its rubber holder inside the fitting, making sure that this part is clean and avoiding to pinch the o-ring.

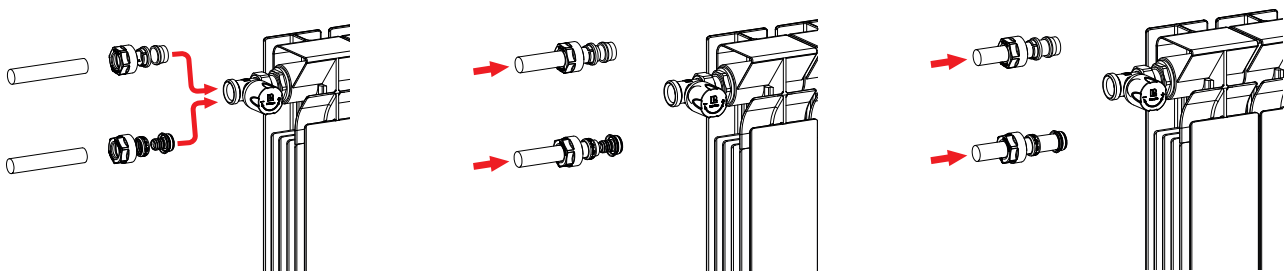

Do not lubricate the rubber parts with oil or mineral based grease: the EPDM compound is compatible only with silicone based lubricants. To avoid any possible mistake, it is advisable to lubricate these parts simply with water.

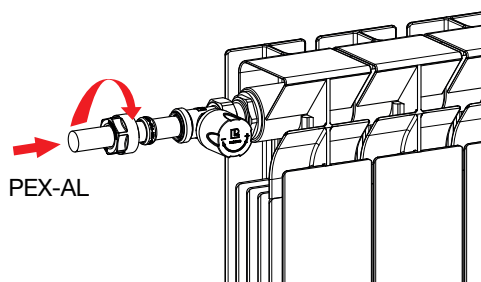
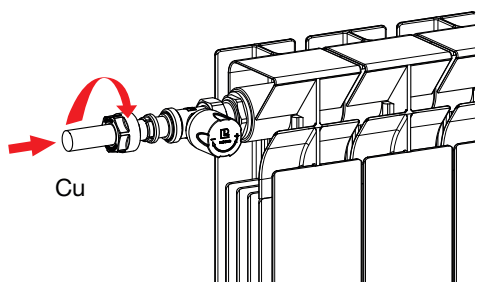
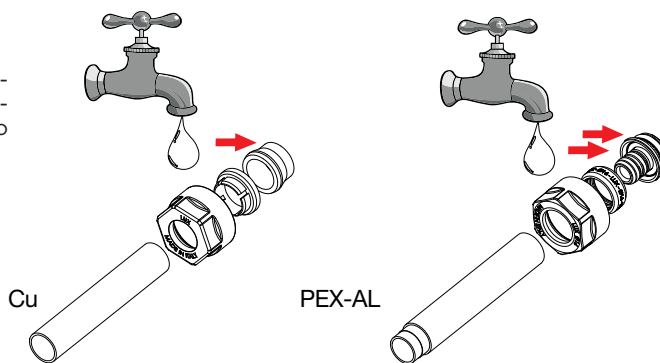

Insert the nut and screw it manually as much as possible and then with a CH 110 key.

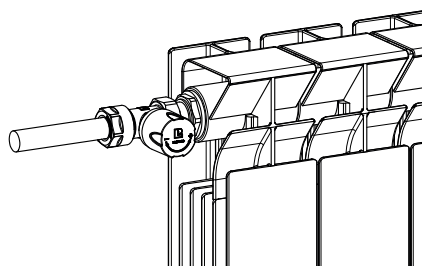
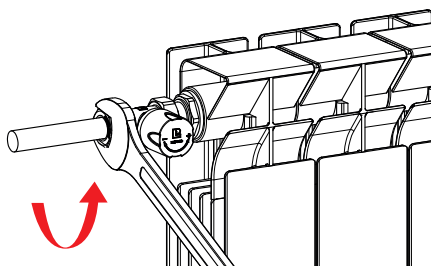

TORQUE

For a correct use of the fittings it is necessary to observe the below chart concerning the nuts torque according to the type of fitting and the type of pipe.



TUBE SIZE	ANNEALED COPPER	SEMI-SOFT COPPER	MILD STEEL	POLYETHYLENE, POLYPROPYLENE, POLYBUTENE	MULTILAYER PEX-AL-PEX
Up to Ø 18 mm	From 35 to 45 Nm	From 60 to 80 Nm	From 60 to 70 Nm	From 40 to 50 Nm	From 25 to 35 Nm
Above Ø 18 mm	-	-	-	From 40 to 50 Nm	From 25 to 35 Nm

FITTINGS FOR COPPER PIPE



TR 92

Compression fitting with brass ogive for copper or mild steel pipe. In compliance with D.M. 174/2004.

CODE	SIZE			
67611400	14 mm	24	100	800
67611500	15 mm	21	100	800

thread G1/2



TR 94

Compression fitting with brass ogive with o-ring for copper or mild steel pipe for underfloor installation.

CODE	SIZE			
67621500	15 mm	20	100	800

thread G1/2



TR 890

Soft compression fitting with PTFE/CV ogive - for copper pipe - thread G1/2.

CODE	SIZE			
68720010	10 mm	26	50	400
68720012	12 mm	25	50	400
68720014	14 mm	20	50	400
68720016	16 mm	19	50	400

thread G1/2



TR 91

Soft compression fitting with EPDM ogive - for copper pipe - thread W24x19.

CODE	SIZE			
67760010	10 mm	52	50	400
67760012	12 mm	44	50	400
67760014	14 mm	42	50	400
67760015	15 mm	40	50	400
67760016	16 mm	38	50	400
67760018	18 mm	36	50	400

thread W24x19



TR 91/A

Soft compression fitting with EPDM ogive - for copper pipe - thread G3/4 **eurokonus.**

CODE	SIZE			
67761000	10 mm	54	40	320
67761200	12 mm	52	40	320
67761400	14 mm	50	40	320
67761500	15 mm	50	40	320
67761600	16 mm	48	40	320
67761800	18 mm	46	40	320

thread G3/4 eurokonus



FITTINGS FOR POLYETHYLENE, POLYBUTYLENE AND POLYPROPYLENE PIPE



TP 93

Compression fitting for polyethylene, polybutilene and polypropylene pipe, thread G 1/2.

CODE	SIZE			
67801208	12 x 2	56	50	400
67801510	15 x 2,5	48	50	400
67801612	16 x 2	45	50	400
67801616	16 x 2,2	44	50	400

thread G1/2



TP 95

Compression fitting for polyethylene, polybutilene and polypropylene pipe, thread W24x19.

CODE	SIZE			
67781008	10,5 x 1,25	62	50	400
67781210	12 x 1	52	50	400
67781209	12 x 1,5	60	50	400
67781208	12 x 2	59	50	400
67781410	14 x 2	60	50	400
67781511	15 x 2	54	50	400
67781510	15 x 2,5	56	50	400
67781613	16 x 1,5	52	50	400
67781612	16 x 2	56	50	400
67781616	16 x 2,2	56	50	400
67781611	16 x 2,5	56	50	400
67781628	16 x 2,8	56	50	400
67781713	17 x 2	50	50	400
67781814	18 x 2	48	50	400
67781813	18 x 2,5	48	50	400
67782016	20 x 2	60	50	400
67782017	20 x 2,8	68	50	400
67782034	20 x 3,4	60	50	400

thread W24x19



TP 98

Compression fitting for polyethylene, polybutilene and polypropylene pipe, thread G3/4 eurokonus.

CODE	SIZE			
67841007	10 x 1,2	76	40	320
67841209	12 x 1,5	76	40	320
67841208	12 x 2	76	40	320
67841410	14 x 2	70	40	320
67841510	15 x 2,5	70	40	320
67841613	16 x 1,5	60	40	320
67841618	16 x 1,8	60	40	320
67841612	16 x 2	60	40	320
67841616	16 x 2,2	68	40	320
67841713	17 x 2	58	40	320
67841814	18 x 2	68	40	320
67842016	20 x 2	57	40	320
67842028	20 x 2,8	64	40	320
67842034	20 x 3,4	60	40	320

thread G3/4 eurokonus

FITTINGS FOR POLYETHYLENE MULTILAYERS PEX-AL-PEX PIPE

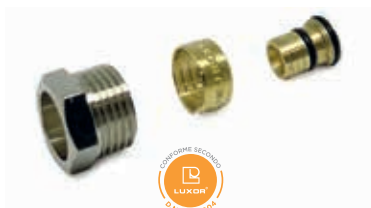

TP 90

Compression fitting for polyethylene multilayer pipe PEX-AL-PEX for G1/2 iron pipe connection.

CODE	SIZE			
67631612	16 x 2	27	50	400

thread G1/2



TP 96

Compression fitting for polyethylene multilayer pipe PEX-AL-PEX, thread G1/2.

CODE	SIZE			
67871410	14 x 2	56	50	400
67871612	16 x 2	57	50	400
67871611	16 x 2,25	52	50	400

thread G1/2



TP 97

Compression fitting for polyethylene multilayer pipe PEX-AL-PEX, thread W24x19.

CODE	SIZE			
67821410	14 x 2	54	50	400
67821612	16 x 2	52	50	400
67821611	16 x 2,25	52	50	400
67821626	16,2 x 3	52	50	400
67821711	17 x 2,75	49	50	400
67821713	17 x 2	50	50	400
67821712	17 x 2,5	50	50	400
67821814	18 x 2	50	50	400
67822016	20 x 2	66	50	400
67822017	20 x 2,25	64	50	400
67822015	20 x 2,5	62	50	400
67822014	20 x 3	62	50	400

thread W24x19

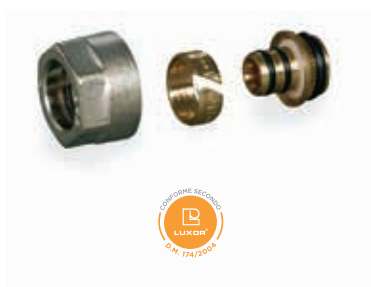

TP 99

Compression fitting for polyethylene multilayer pipe PEX-AL-PEX, thread G3/4 eurokonus.

CODE	SIZE			
67861210	12,2 x 1,3	74	40	320
67861410	14 x 2	78	40	320
67861512	15 x 1,5	63	40	320
67861612	16 x 2	74	40	320
67861611	16 x 2,25	74	40	320
67861610	16,2 x 3	74	40	320
67861713	17 x 2	74	40	320
67861712	17 x 2,5	74	40	320
67861711	17 x 2,75	70	40	320
67861814	18 x 2	74	40	320
67862016	20 x 2	78	40	320
67862017	20 x 2,25	76	40	320
67862015	20 x 2,5	74	40	320
67862014	20 x 3	72	40	320

thread G3/4 eurokonus

CHROME AND PAINTED COMPRESSION FITTINGS FOR COPPER PIPE



CHROME



WHITE



BLACK

TR 91/AC

Soft compression fitting with EPDM ogive - for copper pipe - thread G3/4 eurokonus.

CODE	SIZE	FINISH			
67761000C	10 mm	CHROME	57	20	240
67761200C	12 mm	CHROME	54	20	240
67761400C	14 mm	CHROME	51	20	240
67761500C	15 mm	CHROME	48	20	240
67761600C	16 mm	CHROME	46	20	240
67761000B	10 mm	WHITE	57	20	240
67761200B	12 mm	WHITE	54	20	240
67761400B	14 mm	WHITE	51	20	240
67761500B	15 mm	WHITE	48	20	240
67761600B	16 mm	WHITE	46	20	240
67761000N	10 mm	BLACK	57	20	240
67761200N	12 mm	BLACK	54	20	240
67761400N	14 mm	BLACK	51	20	240
67761500N	15 mm	BLACK	48	20	240
67761600N	16 mm	BLACK	46	20	240

thread G3/4 eurokonus

CHROME-PLATED AND PAINTED COMPRESSION FITTINGS FOR POLYETHYLENE, POLYBUTYLENE AND POLYPROPYLENE PIPE



CHROME



WHITE



BLACK

TP 98/C

Compression fitting for polyethylene, polybutylene and polypropylene pipe, thread G3/4 eurokonus.

CODE	SIZE	FINISH			
67841410C	14 x 2	CHROME	65	20	240
67841612C	16 x 2	CHROME	61	20	240
67841713C	17 x 2	CHROME	58	20	240
67841814C	18 x 2	CHROME	59	20	240
67842016C	20 x 2	CHROME	57	20	240
67841410B	14 x 2	WHITE	65	20	240
67841612B	16 x 2	WHITE	61	20	240
67841713B	17 x 2	WHITE	58	20	240
67841814B	18 x 2	WHITE	59	20	240
67842016B	20 x 2	WHITE	57	20	240
67841410N	14 x 2	BLACK	65	20	240
67841612N	16 x 2	BLACK	61	20	240
67841713N	17 x 2	BLACK	58	20	240
67841814N	18 x 2	BLACK	59	20	240
67842016N	20 x 2	BLACK	57	20	240

thread G3/4 eurokonus

CHROME-PLATED AND PAINTED COMPRESSION FITTINGS FOR POLYETHYLENE MULTILAYERS PEX-AL-PEX PIPE



CHROME



WHITE



BLACK

TP 99/C

Compression fitting for polyethylene multilayer pipe PEX-AL-PEX, thread G3/4 **eurokonus**.

CODE	SIZE	FINISH			
67861410C	14 x 2	CHROME	67	20	240
67861612C	16 x 2	CHROME	65	20	240
67861611C	16 x 2.25	CHROME	60	20	240
67861713C	17 x 2	CHROME	60	20	240
67861814C	18 x 2	CHROME	61	20	240
67862016C	20 x 2	CHROME	59	20	240
67861410B	14 x 2	WHITE	67	20	240
67861612B	16 x 2	WHITE	65	20	240
67861611B	16 x 2.25	WHITE	60	20	240
67861713B	17 x 2	WHITE	60	20	240
67861814B	18 x 2	WHITE	61	20	240
67862016B	20 x 2	WHITE	59	20	240
67861410N	14 x 2	BLACK	67	20	240
67861612N	16 x 2	BLACK	65	20	240
67861611N	16 x 2.25	BLACK	60	20	240
67861713N	17 x 2	BLACK	60	20	240
67861814N	18 x 2	BLACK	61	20	240
67862016N	20 x 2	BLACK	59	20	240

thread G3/4 eurokonus

IN-WALL CONNECTIONS FOR THE DISTRIBUTION WITH REMOVABLE PIPES

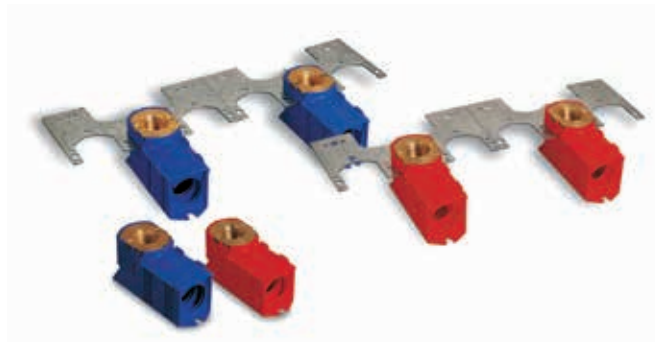

CONSTRUCTIVE FEATURES

Luxor in-wall connections are designed to meet the modern necessity to use removable plastic pipes in heating and sanitary distribution systems.

The main features of these products are:

- easy pipe laying;
- possibility of doing maintenance without damaging the walls, working inside the plastic boxes which isolate the connections from the plaster;
- low noise of the system thanks to the absence of junctions which create noise;
- aesthetic quality of the end result.

The fittings are produced in DZR brass CW626N UNI EN 12165:2016. All gaskets are in peroxide cured EPDM. The plastic boxes containing the connections consist of talc filled polypropylene.

By using the chrome-plated copper connection pipe M 528, the tightness is guaranteed by o-rings and the aesthetic effect ensured by a chrome-plated pipe always aligned both with

TECHNICAL DATA



Max temperature

120 °C



Max pressure

10 bar

the fitting and the wall.

The brackets SS 1982 are in galvanised iron Fe Z100 EN 10142-92 and divisible.

These items allow to lay the connections quickly and safely, at the required depth and with the correct interaxes for the connection to sanitary appliances.

All the fittings for copper and plastic pipes are supplied without assembled fittings.



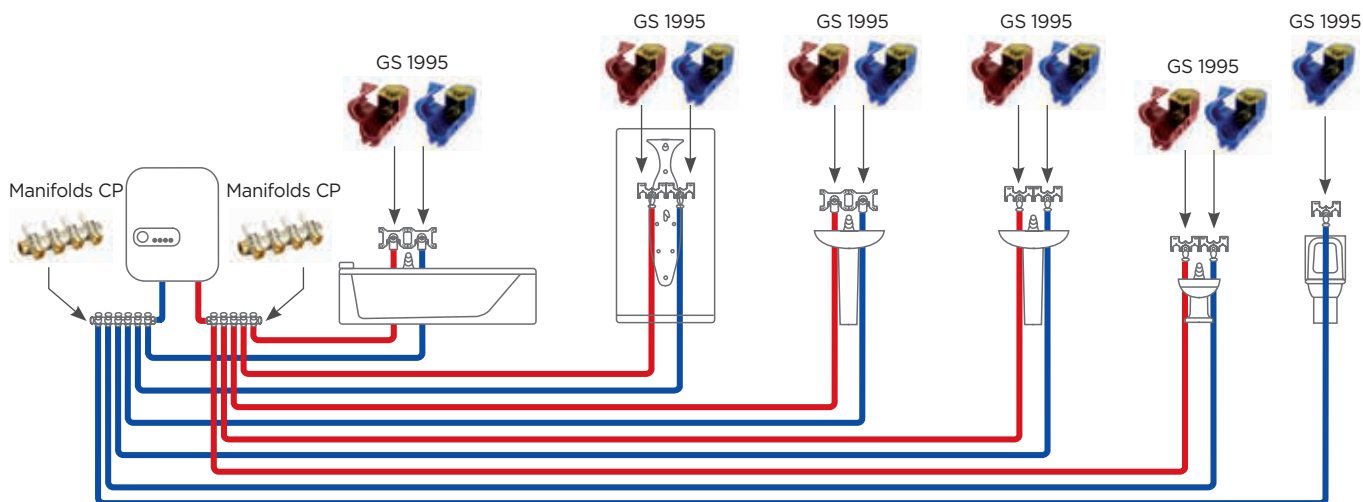

SANITARY DISTRIBUTION SYSTEM WITH ONE INLET FOR EACH USER POINT

This is the most common type of system, each user point is directly connected to one outlet of the distribution manifold.

The **advantages** of this type of system are:

- constant pressure for each user point;
- possibility to adjust the flow rate for each single user point;
- easy maintenance.

The **disadvantages** are:

- a very large quantity of pipes used;
- large distribution boxes.

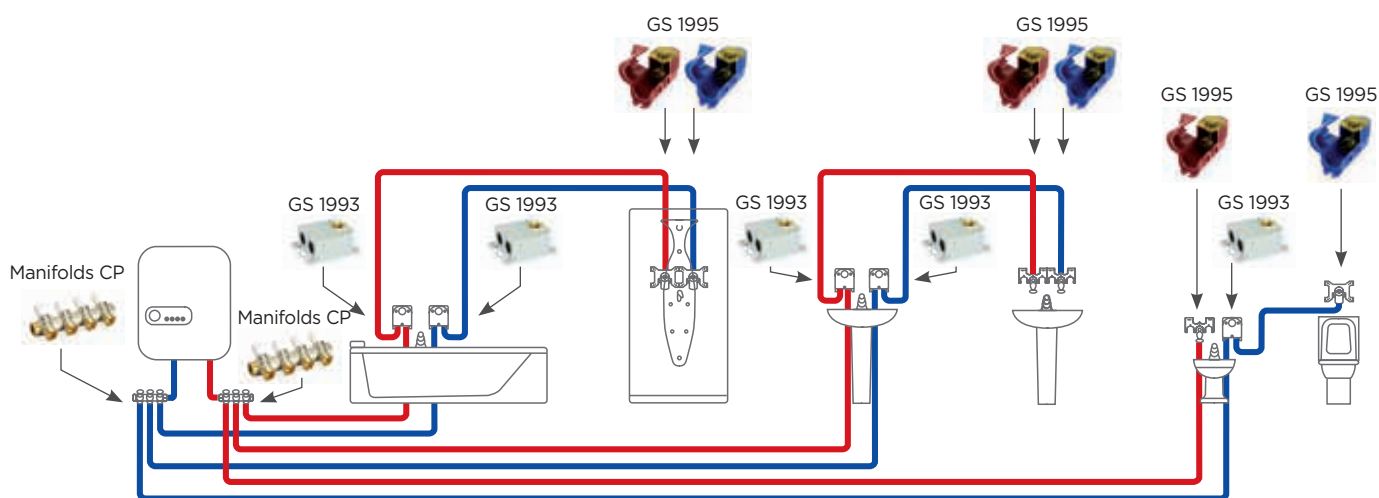

BLOCK SANITARY DISTRIBUTION SYSTEM

In this type of system, the user point are divided in groups.

The **advantages** are:

- low implementation costs;
- less space occupied by pipes and distribution box.

The **disadvantages** are:

- in case of simultaneous use, the flow is subdivided among the user points.

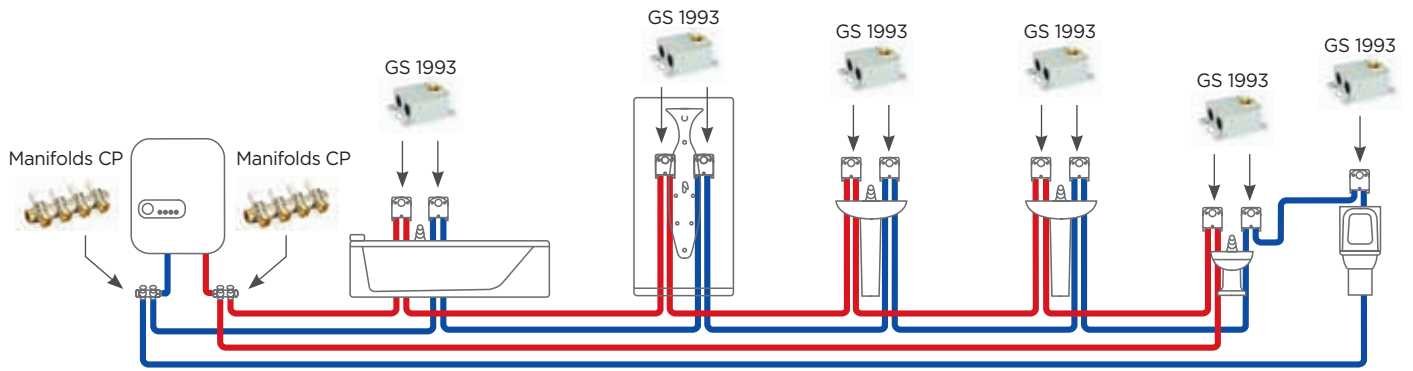

SINGLE-PIPE SYSTEM FOR SANITARY DISTRIBUTION

This type of system is the simplest.

The **advantages** of this type of system are:

- ease of construction;
- minimum space for pipes and distribution box;
- low construction cost.

The **disadvantages** are:

- in case of simultaneous use, the flow is subdivided among the user points.

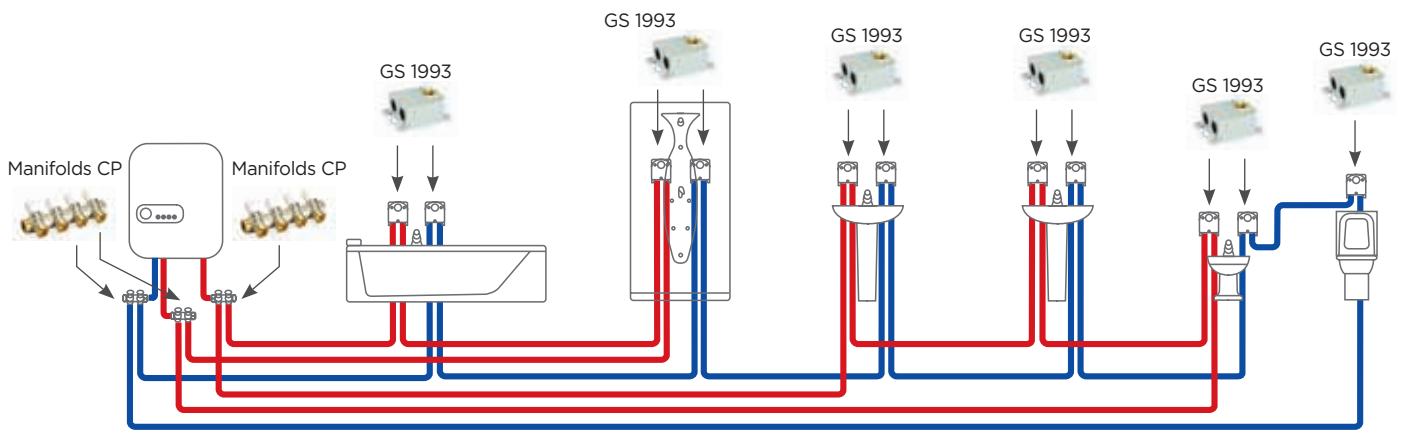

SANITARY DISTRIBUTION SYSTEM WITH COMFORT RECIRCULATION

This type of system creates a recirculation for hot water.

The **advantages** of such a system are:

- maximum comfort, since the hot water is immediately available, no matter the distance from the boiler;

The **disadvantages** are:

- high implementation costs;
- use of insulated pipes to reduce the heat loss;
- need to create a specific recirculation circuit.

IN-WALL CONNECTIONS FOR THE DISTRIBUTION WITH REMOVABLE PIPES

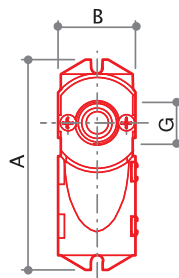

GS 1995

90° in-wall single elbow fitting, blue or red, without bracket, with brass cap and o-ring for tightness testing.

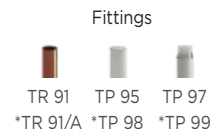

CODE	SIZE	A	B	C	D	E	F	G	H	L			
66004100B	G 1/2 x (W24x19)	104	38	50	-	-	W24x19	G 1/2	-	-	124	8	64
66004100R	G 1/2 x (W24x19)	104	38	50	-	-	W24x19	G 1/2	-	-	124	8	64
66004102B*	G 1/2 x G 3/4 EK	104	38	50	-	-	G 3/4 EK	G 1/2	-	-	127	8	64
66004102R*	G 1/2 x G 3/4 EK	104	38	50	-	-	G 3/4 EK	G 1/2	-	-	127	8	64



RC 914

90° in-wall elbow fitting.

CODE	SIZE	FINISHING						
68549899	G 1/2 x (W24x19)	YELLOW SURFACE	TR 91	TP 95	TP 97	75	30	240
68549901	G 1/2 x G 3/4 EK	YELLOW SURFACE	TR 91/A	TP 98	TP 99	78	30	240
68549899N	G 1/2 x (W24x19)	NICKEL-PLATED	TR 91	TP 95	TP 97	75	30	240
68549901N	G 1/2 x G 3/4 EK	NICKEL-PLATED	TR 91/A	TP 98	TP 99	78	30	240

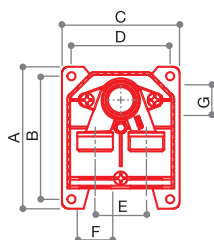

CS 1993

Double connection, single pipe system, with in-wall housing.

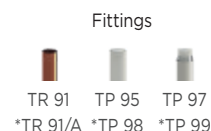

CODE	SIZE	A	B	C	D	E	F	G	H	L			
66002200	G 1/2 x (W24x19)	105	91	87	73	38	W24x19	G 1/2	-	-	288	6	48
66002201*	G 1/2 x G 3/4 EK	105	91	87	73	38	G 3/4 EK	G 1/2	-	-	294	6	48

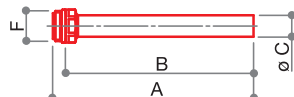

M 528

Chrome-plated copper connection pipe with soft seal for in-wall distribution boxes.

CODE	SIZE	A	B	C	D	E	F	G	H	L			
67510015	G 1/2 x (Ø 15 x 140)	140	131	15	-	-	G 1/2	-	-	-	70	35	280
67520015	G 1/2 x (Ø 15 x 175)	175	166	15	-	-	G 1/2	-	-	-	80	30	240

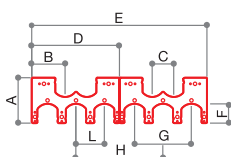

SS 1982

Double bracket, divisible into two single brackets, for in-wall connections GS 1995, GS 1996, interaxis 38-50-100-153.

CODE	SIZE	A	B	C	D	E	F	G	H	L			
66004000	-	80	58	38	154	308	34	100	153	50	142	25	150

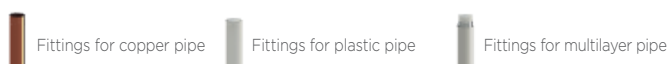

FITTINGS FOR COPPER, PLASTIC AND MULTILAYER PIPE



TECHNICAL DATA



Max temperature

120 °C



Max pressure

10 bar

CONSTRUCTIVE FEATURES

Luxor fittings come in raw (yellow) or nickel plated brass of the following types:

- dezincification resistant CW626N UNI EN 12165:2016
- with limited lead content as prescribed by current standards: CW617N UNI EN 12165:2016.

O-rings and gaskets are in peroxide cured EPDM.

The bracket SS 1984 consists of galvanised iron Fe Z100 EN 10142-92.

This item allows for a quick and safe installation of the fittings with the correct interaxes.

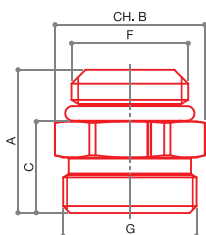

RD 900

Straight fitting with o-ring for connection to distribution manifolds CD series.

Fittings

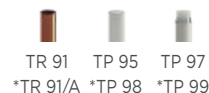

CODE	SIZE	A	B	C	D	E	F	G	H	L	FINISHING			
68559824	G 1/2 x (W24x19)	26	24	16.5	-	-	G 1/2	W24x19	-	-	YELLOW SURFACE	42	50	400
68552700*	G 1/2 x G 3/4 EK	26	27	17	-	-	G 1/2	G 3/4 EK	-	-	YELLOW SURFACE	51	50	400
68559817N**	G 3/8 x (W24x19)	24	24	15	-	-	G 3/8	W24x19	-	-	NICKEL-PLATED	36	100	800
68559824N	G 1/2 x (W24x19)	26	24	16.5	-	-	G 1/2	W24x19	-	-	NICKEL-PLATED	42	50	400
68552700N*	G 1/2 x G 3/4 EK	26	27	17	-	-	G 1/2	G 3/4 EK	-	-	NICKEL-PLATED	51	50	400

** Discontinued article

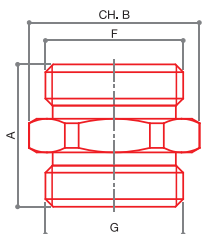

RD 902

Straight fitting M-M.

Fittings

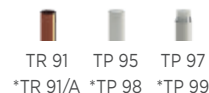

CODE	SIZE	A	B	C	D	E	F	G	H	L			
68549824N	G 1/2 x (W24x19)	32.5	24	-	-	-	R 1/2	W24x19	-	-	46	50	400
68549827N	G 3/4 x (W24x19)	27	27	-	-	-	G 3/4 EK	W24x19	-	-	46	50	400
68559822N	(W24x19) x (W24x19)	26.5	24	-	-	-	W24x19	W24x19	-	-	42	50	400
68559823N*	G 3/4 EK x G 3/4 EK	27.5	30	-	-	-	G 3/4 EK	G 3/4 EK	-	-	62	50	400



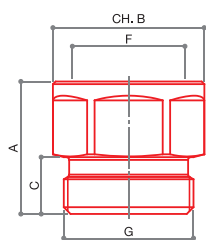

RD 903
Straight fitting F-M.

Fittings



CODE	SIZE	A	B	C	D	E	F	G	H	L			
68549838N	G 1/2 x (W24x19)	24.5	25	10.5	-	-	G 1/2	W24x19	-	-	42	50	400
68549739N*	G 1/2 x G 3/4 EK	26	27	10.5	-	-	G 1/2	G 3/4 EK	-	-	60	50	400
68549743N*	G 3/4 x G 3/4 EK	25	30	10.5	-	-	G 3/4	G 3/4 EK	-	-	51	50	400
68549740N	G 3/4 x (W24x19)	25	31	10.5	-	-	G 3/4	W24x19	-	-	58	50	400
68549741N	(W24x19) x (W24x19)	25	27	10	-	-	W24x19	W24x19	-	-	48	50	400
68549742N**	(W24x19) x G 1/2	24	27	10	-	-	W24x19	G 1/2	-	-	40	50	400

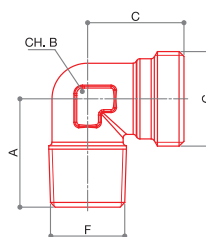

RC 904
Elbow fitting M-M.

Fittings

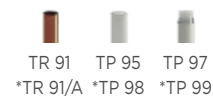

CODE	SIZE	A	B	C	D	E	F	G	H	L			
68549847N	G 1/2 x (W24x19)	30	20	27	-	-	R 1/2	W24x19	-	-	64	50	400
68549746N*	G 1/2 x G 3/4 EK	30	20	27	-	-	R 1/2	G 3/4 EK	-	-	70	30	240

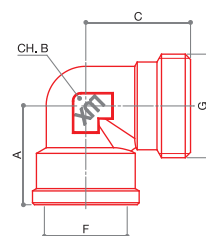

RC 905
Elbow fitting F-M.

Fittings

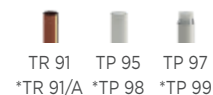

CODE	SIZE	A	B	C	D	E	F	G	H	L			
68549856N	G 1/2 x (W24x19)	25	20	26.5	-	-	G 1/2	W24x19	-	-	79	50	400
68549755N*	G 1/2 x G 3/4 EK	25	20	26.5	-	-	G 1/2	G 3/4 EK	-	-	76	30	240
68549757N*	G 3/4 x G 3/4 EK	36.5	25	33	-	-	G 3/4	G 3/4 EK	-	-	148	25	200

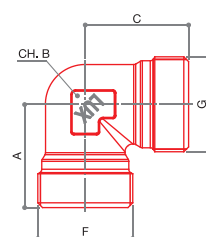

RC 906
Elbow fitting M-M.

Fittings

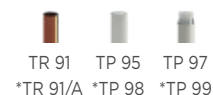

CODE	SIZE	A	B	C	D	E	F	G	H	L			
68549865N	(W24x19) x (W24x19)	26	20	26	-	-	W24x19	W24x19	-	-	62	50	400
68549747N*	G 3/4 EK x G 3/4 EK	33	25	33	-	-	G 3/4 EK	G 3/4 EK	-	-	145	25	200



Fittings for copper pipe



Fittings for plastic pipe



Fittings for multilayer pipe

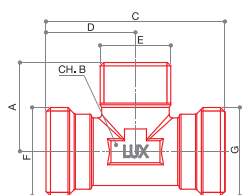

RT 907
T fitting MxMxM.

Fittings

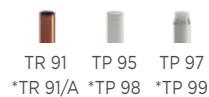

CODE	SIZE	A	B	C	D	E	F	G	H	L			
68549870N	G 1/2 x (W24x19) x (W24x19)	30	20	53	26.5	G 1/2	W24x19	W24x19	-	-	82	30	240
68549770N*	G 1/2 x G 3/4 EK x G 3/4 EK	27	20	53	26.5	G 1/2	G 3/4 EK	G 3/4 EK	-	-	86	25	200

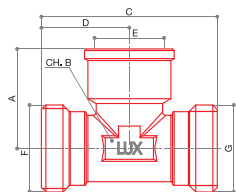

RT 908
T fitting FxMxM.

Fittings

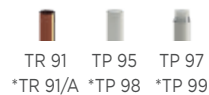

CODE	SIZE	A	B	C	D	E	F	G	H	L			
68549879N	G 1/2 x (W24x19) x (W24x19)	30	20	53	26.5	G 1/2	W24x19	W24x19	-	-	98	30	240
68549779N*	G 1/2 x G 3/4 EK x G 3/4 EK	30	20	53	26.5	G 1/2	G 3/4 EK	G 3/4 EK	-	-	96	25	200

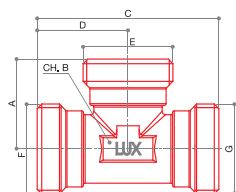

RT 911
T fitting.

Fittings

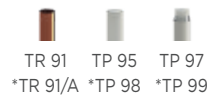

CODE	SIZE	A	B	C	D	E	F	G	H	L			
68549890N	(W24x19) x (W24x19) x (W24x19)	26.5	20	53	26.5	W24x19	W24x19	W24x19	-	-	78	30	240
68549790N*	G 3/4 EK x G 3/4 EK x G 3/4 EK	26.5	20	53	26.5	G 3/4 EK	G 3/4 EK	G 3/4 EK	-	-	96	25	200

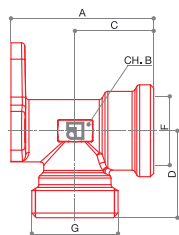

RC 912

Wall elbow fitting with flange.

Fittings

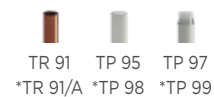

CODE	SIZE	A	B	C	D	E	F	G	H	L			
69549895N	G 1/2 x (W24x19)	43	19	24	26.5	-	G 1/2	W24x19	-	-	109	30	240
69549795N*	G 1/2 x G 3/4 EK	43.5	19	24	26.5	-	G 1/2	G 3/4 EK	-	-	100	25	200
69549794N*	G 3/4 x G 3/4 EK	57	21	37	27	-	G 3/4	G 3/4 EK	-	-	138	20	160

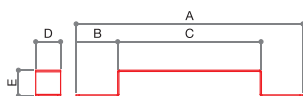

SS 1984

Bracket for wall fitting with flange art.
RC 912 and RM.

CODE	SIZE	A	B	C	D	E	F	G	H	L			
66001200	-	382	70	242	42	43.5	-	-	-	-	280	-	50



RD 923

Straight fitting with male connection and fixed rubber holder for multilayer pipe.

CODE	SIZE			
69549925N	G 3/4 x 25 x 2,5	170	15	120
69549926N	G 3/4 x 26 x 3	172	15	120
69549927N	G 1" x 32 x 3	255	12	96



RC 480

3-piece elbow fitting with o-ring.

CODE	SIZE	FINISHING			
67952100	G 1/2	YELLOW SURFACE	128	25	200
67952700	G 3/4	YELLOW SURFACE	212	15	120
67953400	G 1"	YELLOW SURFACE	372	8	64
67952100N	G 1/2	NICKEL-PLATED	128	25	200
67952700N	G 3/4	NICKEL-PLATED	212	15	120
67953400N	G 1"	NICKEL-PLATED	372	8	64



**RD 482**

3-piece straight fitting with o-ring.

CODE	SIZE	FINISHING			
67972100	G 1/2	YELLOW SURFACE	105	30	240
67972700	G 3/4	YELLOW SURFACE	175	15	120
67973400	G 1"	YELLOW SURFACE	303	12	96
67972100N	G 1/2	NICKEL-PLATED	105	30	240
67972700N	G 3/4	NICKEL-PLATED	175	15	120
67973400N	G 1"	NICKEL-PLATED	303	12	96



**RC 481**

Nickel-plated 3-piece elbow fitting with double o-ring.

CODE	SIZE			
67952101N	G 1/2	128	20	160
67952701N	G 3/4	212	12	96
67953401N	G 1"	372	6	48

**RD 483**

Nickel-plated 3-piece straight fitting with double o-ring.

CODE	SIZE			
67972101N	G 1/2	106	25	200
67972701N	G 3/4	162	12	96
67973401N	G 1"	256	10	80

**CH 110**

Wrench key for compression fittings.

CODE	SIZE			
67822724	CH 24-27 mm	352	10	80

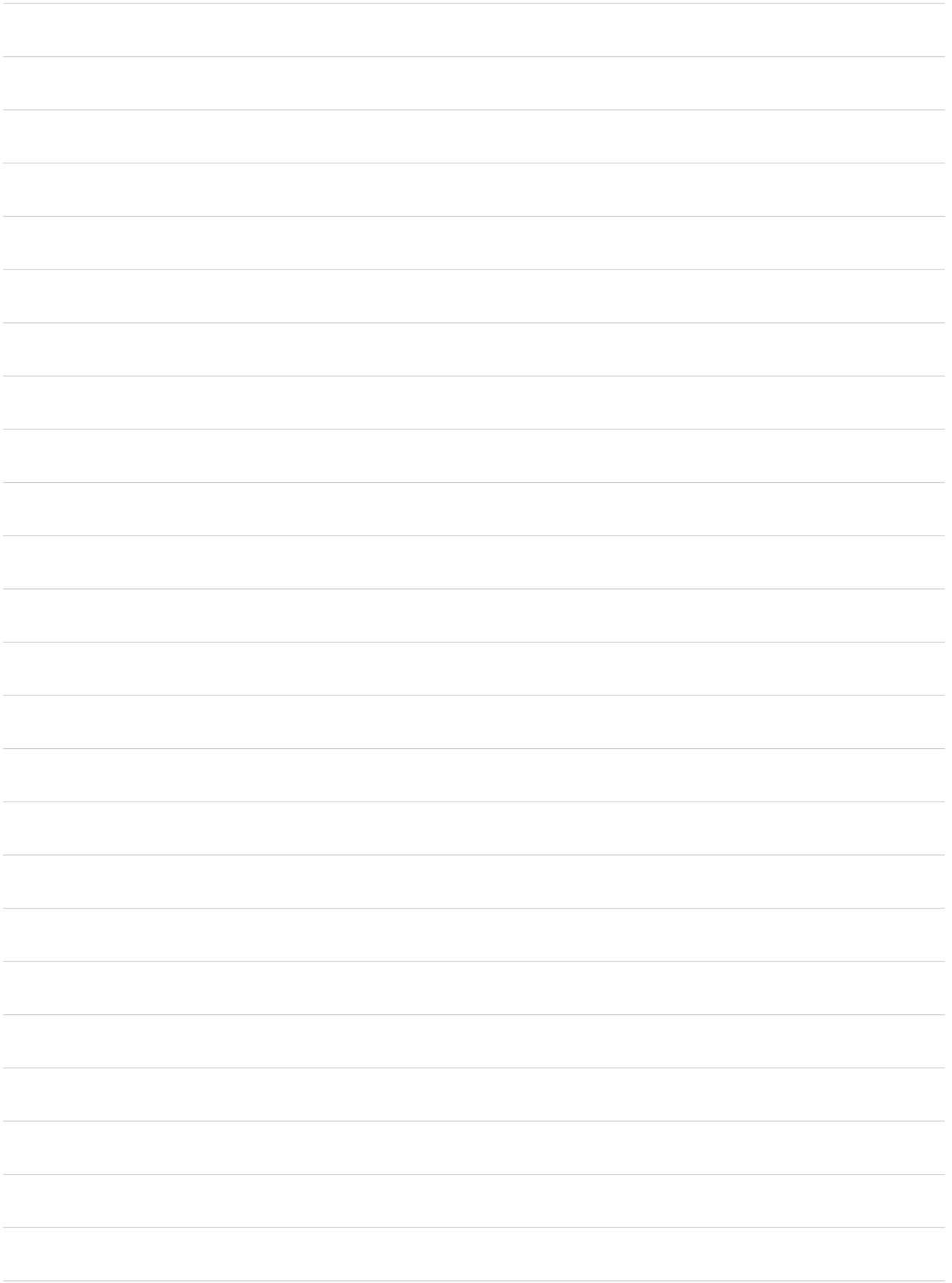

GENERAL CONDITIONS OF SALE

1 PREMISES - 1.1 The present conditions of sale apply to all supplies of Luxor Spa Products (hereafter "Luxor"). Any general conditions, and in particular the conditions of purchase of the Buyer (hereafter "Customer"), unless expressly accepted in writing by Luxor, shall not bind the latter nor exempt the Customer from the application of the present General Conditions (hereafter GSC)

2. ORDERS - 2.1 The Purchase Orders (referred to as 'Orders') are an irrevocable purchase proposal. By placing an Order, customers fully accept the present General Conditions of Sale.

2.2 Orders are considered accepted only after Luxor confirms them in writing. The Order confirmation and/or Invoice issued by Luxor will be considered as confirmation.

2.3 Any changes to the Order requested by the Customer after the sending of the Order Confirmation will only be valid and enforceable after written acceptance by Luxor. Cancellation or modification of Orders without the prior written consent of Luxor, will give Luxor the right to act to obtain reimbursement of the costs incurred, without prejudice to the right to compensation for greater damages.

3 PRICES - 3.1 Luxor products will be invoiced based on the current price list at the time the order is accepted. Prices do not include VAT or any other taxes.

3.2 Prices listed in sales catalogues/lists are merely indicative and may be subject to change due to production cost increases. In such cases, Luxor will inform the purchaser of the price increase and provide the reasons.

4 DELIVERY TERMS - 4.1 The supplies in each individual Order will be delivered within the stated terms in the Order Confirmation.

4.2 Luxor will not be held responsible for delays in delivery that are not caused by Luxor, such as delays by third parties, including suppliers and sub-suppliers, shippers, and causes of force majeure that result in total or partial inactivity of the plants. In the cases mentioned above, the Customer cannot refuse delivery of the goods, even if it is only partial, nor can they use a delay in delivery as a reason to terminate the contract or claim damages.

5 SHIPMENTS - 5.1 The products will be delivered to the 'Assigned Port' (Incoterms 2020 EXW), with transport costs and risks borne by the buyer, unless otherwise agreed.

5.2 Even in the case of agreed delivery in "Free Port" (Incoterms 2020 DDP) with costs borne by Luxor, the goods will still travel at the buyer's risk. Regardless of the delivery terms agreed upon by the parties, the risks will pass to the buyer at the latest with delivery to the first carrier.

5.3 The transfer of ownership of the goods is suspended until the full price has been paid, but this does not affect the transfer of risk to the purchaser.

5.4 If special packaging is required, an additional charge as indicated in the price list or order confirmation will be added to the invoice.

6 PAYMENTS - 6.1 Payments are due as per the terms and manner specified in the order confirmation and/or invoice.

6.2 Unless otherwise expressly agreed, payments must be made to the bank details mentioned in the sales invoice. For payments made from abroad via bank transfer, the OUR option must be selected to ensure that Luxor receives the net amount on the invoice after deducting bank charges and expenses. Luxor does not authorize any third parties, including agents and representatives, to collect money on its behalf.

6.3 The Customer is not permitted to suspend or delay payments, even in the event of claims or complaints of defects, and must adhere to the agreed terms.

6.4 In case of payment interruption or suspension, the Customer will be considered in default. Luxor reserves the right to charge expenses and interest as per Art. 5 and 6 of D.Lgs n. 192/2012, without prejudice to the right to terminate the contract. Delayed payment may also result in Luxor excluding the guarantee for the entire period of delay.

6.5 If the Customer fails to adhere to the agreed payment terms, or interrupts or suspends payment, Luxor reserves the right to suspend any ongoing supplies and/or make the execution of the current order conditional on the payment of the outstanding debt. Luxor may also withdraw from any further contracts with the Customer and cancel any previously granted favourable conditions, such as discounts or free gifts.

6.6 The Customer is not permitted to offset any claims they may have against Luxor with debts they owe to Luxor, unless formally authorised by Luxor

7 EXPRESS TERMINATION CLAUSE - 7.1 Luxor may terminate the contract immediately if the Customer is undergoing bankruptcy or liquidation proceedings, as well as in the event that the Customer is subject to execution proceedings and/or protests and the economic conditions suggest the purchaser is insolvent.

8 WARRANTY - 8.1 Luxor guarantees the conformity of the products supplied, free from defects that could make them unsuitable for their intended use. The guarantee may be invoked if the defect is due to

manufacturing errors or defects in raw materials that are the responsibility of Luxor.

8.2 Unless otherwise expressly agreed, the guarantee lasts for one (1) year from the date of delivery. The Customer must make a written complaint within eight (8) days from delivery in the case of apparent defects, or, in the case of hidden defects, from the time of discovery and in any event not later than twelve (12) months from delivery.

8.3 In the event of non-conforming products, Luxor may, at its discretion, provide the Buyer with replacement products of the same type and quantity free of charge ex works, after verifying the returned products. Any return must always be previously agreed and authorised by Luxor. The goods in question must be returned 'carriage paid' along with a note explaining the reason for the return within 30 days of Luxor's approval. Failure to do so will result in the authorization becoming invalid.

8.4 If Luxor does not recognize the defective products upon verification, it will invoice those sent as replacements. If Luxor does not recognize the defective products upon verification, they will invoice the replacements. If Luxor is unable to replace defective products, they may issue a credit note to the customer for the value of the defective products. This does not imply any responsibility on Luxor for direct, indirect, or consequential damages resulting from or connected to the defects or faults of the products.

8.5 It is important to note that this guarantee does not cover instances where the product has been installed, used or maintained in a manner that is contrary to the instructions and warnings provided in the installation, use, and maintenance manuals that were included with the product. Additionally, any installation or repair work should only be carried out by qualified personnel.

8.6 The guarantee will not apply if the Purchaser breaches their contractual obligations.

8.7 This warranty is the only warranty and replaces any other written, oral or implied warranties. By accepting these General Terms and Conditions, the Purchaser expressly waives any right of recourse arising from the sale and/or installation of the Products to a non-professional consumer.

9. RESERVATION OF PROPERTY 9.1 The sale of Luxor S.p. A's Products is carried out under reservation of ownership. Therefore the products will remain the property of Luxor S.p.A. until the full payment of the price by the buyer.

10 TRANSFER OF THE CONTRACT 10.1 It is forbidden to transfer the Contract and/or any interest, right and obligation connected to it to third parties without specific written approval by Luxor.

11 PRIVACY - 11.1 The Customer confirms that they have read the information regarding the processing of their personal data, as required by Articles 13 and 14 of Regulation (EU) 2016/679 (GDPR) as amended. The information can be found at <https://luxor.it/privacy-policy>. By accepting these GTC, the Customer consents to the processing of their personal data.

11.2 Luxor will process the personal data provided by the Customer, including through external parties, to fulfil legal obligations and carry out administrative and commercial tasks related to the contractual relationship.

12 APPLICABLE LAW AND COURT OF JURISDICTION - 12.1 Contract is governed by Italian law. Anything not expressly governed by these GVCs shall be governed by the rules on sale provided for in articles 1470 et seq. of the Italian Civil Code.

12.2 The Parties expressly exclude the application of the Vienna Convention on Contracts for the International Sale of Goods. Any disputes related to the Contract, including those regarding its validity, interpretation, execution, and termination, must be referred exclusively to the Court of Brescia.

12.3 Luxor reserves the right to take legal action at the competent court of the Customer's location to recover any outstanding debts. The local law will apply in this case.

13 FINAL CLAUSES - 13.1 The possible nullity and/or ineffectiveness of one or more provisions of these GTC shall not affect the validity of the Contract as a whole.

13.2 Any amendment to the Contract shall be valid only if made in writing and signed by authorised representatives of both Parties.

The customer acknowledges that they are not a 'consumer' and therefore the provisions of law relating to relations between entrepreneurs and consumers do not apply. The customer declares that they have paid particular attention to the following clauses: Introduction (1.1), Orders (2.1-2.3), Prices (3.2), Delivery Terms (4.1-4.2), Shipping (5.1-5.3), and 6. The following sections require approval: Payments (6.2 - 6.3 - 6.4 - 6.5 - 6.6); 7 Express Termination Clause (7.1); 8 Warranty (8.1 - 8.2 - 8.3 - 8.4 - 8.5 - 8.6 - 8.7); 9. Retention of Title (9.1); 10. Applicable Law and Jurisdiction (12.1 - 12.2 - 12.3); 13 Final Clauses (13.1 - 13.2), and they are to be specifically approved.

These general terms and conditions are published on LUXOR's website (<https://luxor.it/>) where they may be consulted, thereby taking full and proper cognisance thereof, pursuant to and for the purposes of Articles 1341 and 1342 of the Civil Code.