



## 60 YEARS OF ITALIAN TRADITION

Luxor is an important industrial reality, world wide and European market leader in the production of flexible hoses and components for hydro and thermo-sanitary installations. Luxor has been the expression of the most prestigious made in Italy and the great Italian high technology mechanical workings tradition for fifty years; a quality certified and recognized by the most prestigious International Certification Institutes all over the world.

Our mission is the complete customer satisfaction through a process of continuous technological research in order to make high quality, reliable products, anticipating the market evolutions by innovative partnership with both customers and suppliers. Luxor mission takes

place in its own Research and Development Centre in which new and advanced technologies are constantly analyzed and researched with continuous investments to offer the most innovative and reliable solutions for the international markets at competitive costs, ensuring strict quality controls on each single piece.

Luxor entirely plans and realizes each product, thanks to its decennial know how. The great production strength, a "slender" innovative and advanced industrial organization together with a modern logistic conception, make Luxor able to satisfy every kind of request, even customized, with fast deliveries all over the world.



Luxor is certified ISO 9001:2015 by DEKRA Group certification body

### CERTIFICATION



Please contact our offices for information about technical specifications and certified products or visit the website of the corresponding certification body for the latter.

Please refer to [www.nsf.org](http://www.nsf.org) for a complete list of NSF approved products.  
Please refer to [www.iapmort.org](http://www.iapmort.org) for a complete list of UPC/CUPC approved products.



LUXOR®

## 6 / MODULAR HYDRONIC SYSTEM

## MODULAR HYDRONIC SYSTEM



The modular hydronic system consists of:

- a modular distribution manifold;
- pumping groups;
- fixed-points mixing and pumping groups;
- mixing and pumping groups with sliding temperature.

The modular hydronic system SIM 1208 is used in the distribution and operation of zone systems. It was developed to create several solutions aimed at simplifying and solving various installation issues. All components in contact with water are in brass or stainless steel and the gaskets in peroxide cured EPDM. The use of these metals prevents the bimetallic corrosion occurring with metals of different nobility.

The manifold can be connected to the boiler from any direction. In this way, it is possible to connect one or more energy sources at the same time, such as a boiler and a refrigeration group. The whole system can easily be assembled on site. The manifold is modular, so it can be composed with a number of elements according to the system requirements. Each module of the manifold can be assembled so as to have the connections to the groups both on the left or the right, thus being adaptable to the existing system.

Thermomanometers, air vent valves, water inlet/outlet valves, expansion vessels and safety groups can be installed on the free connections of the manifold.

Each pumping group can be installed either with left or right connections. Each mixing and pumping group is provided with thermometers to read the inlet and outlet temperature, a differential bypass valve for the pump installed on the groups and seats for regulation and reading probes. The mixing groups can be connected directly to the boiler (without manifold) and act as a pumping and mixing unit.

Mixing groups feature a 3-way piston mixing valve for fixed-point or sliding adjustment. The mixing valve is also equipped with two bypasses, one before and one after the mixing. Mixing groups are provided with a safety thermostat with immersion probe and housing.

The SIM 1208 can be installed in a metal cabinet and, if needed, hung to the wall through its brackets. All versions of the SIM 1208 are extremely compact.

It allows to install up to 5 G 1"1/4 groups in 700 mm of width, and up to 6 if the boiler is connected on one side. With the pumps placed horizontally, the depth of the system is only 100 mm.

### TECHNICAL DATA

Maximum working pressure 6 bar  
Maximum working temperature 80 °C  
Mixing Kvs value 5,5 (recirculation) – 6.9 (primary exchange)

### CONSTRUCTIVE FEATURES

#### Manifold

Brass manifold, material:  
CB 753 S UNI EN 1982-2000 for faucets  
Connection kit for modules, material:  
CW614N UNI EN 12164:2016  
Gasket, material:  
Peroxide cured EPDM

#### Mixing unit

Flow meter, material:  
Brass CB 753 S UNI EN 1982- 2000 for faucets  
Gasket, material:  
Peroxide cured EPDM  
Brass parts of the screw, material:  
CW614N UNI EN 12164:2016  
Steel parts of the screw, material:  
Stainless steel

#### Probe holder group

Brass manifold, material:  
CB 753 S UNI EN 1982-2000 for faucets  
Components material:  
CW614N UNI EN 12164:2016  
Max recommended flow to mixing valve 2.750 l/h  
( $\Delta p$  0.25bar)  
Thermometer range 0÷ 80 ° C

#### Thermometers

Thermometer case and stem in galvanized steel  
Covering in transparent plastic material  
Thermometric element bimetallic spring

#### Pumps

Wilo Yonos Para RS 25/6-130-FSM-RKA-12  
Wilo Stratos Para 25/1-7-130 T3  
Wilo Stratos Para 25/1-8-130 T3

### GALVANIC TREATMENTS

Nickel plating

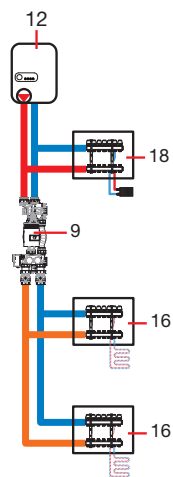
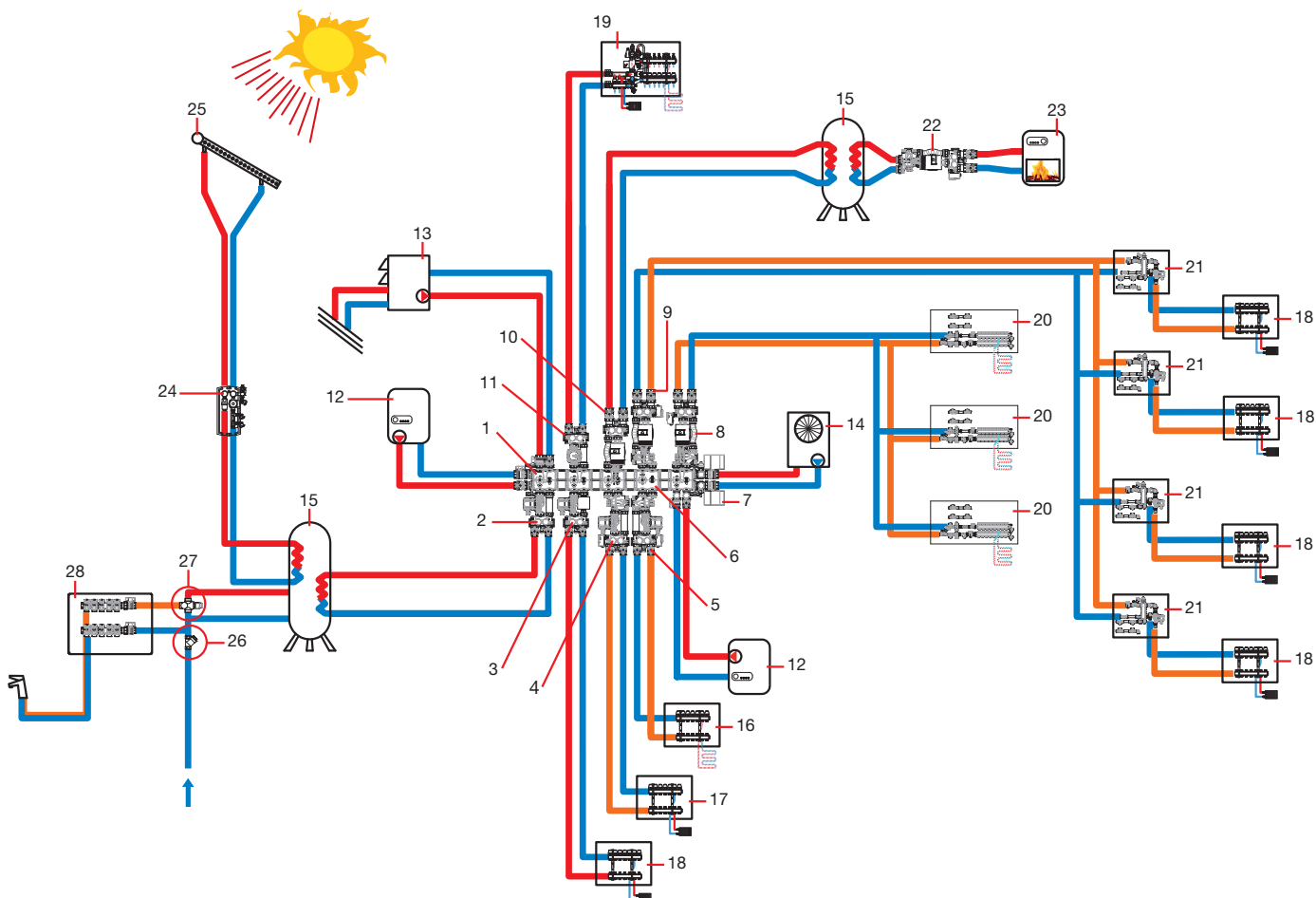

- 1 Manifold CD 1210
- 2 Pumping unit G 1" GR 112-GR 1230
- 3 Pumping unit G 1" GR 1220 - GR1230 with heat meter G 3/4 interaxis 110 mm
- 4 Mixing group G1" with left inlet GM 1260 - GM1270
- 5 Mixing group G1" with right inlet GM 1260 - GM1270
- 6 Manifold CD 1210 assembled backhand to invert the connection of the pumping/mixing unit (right inlet)
- 7 Zone Valve VZ 700
- 8 Mixing group G 1" 1/4 installed with right inlet GM 1260 - GM 1270
- 9 Mixing group G 1" 1/4 installed with left inlet GM 1260 - GM 1270
- 10 Pumping unit G 1 1/4 GR 1220 - GR 1230
- 11 Pumping unit G 1" GR 1220 - GR 1230
- 12 Boiler
- 13 Heat pump
- 14 Refrigeration group
- 15 Heater
- 16 Manifold CD 2468 for distribution in radiant panels system
- 17 Manifold CD 2468 for distribution in Fan coil system
- 18 Manifold CD 2468 for distribution in Fan coil system
- 19 Complete pre-assembled distribution group for high temperature, fixed-point mixing and pumping
- 20 Pre-assembled group MC 5001 designed for heat and sanitary water metering, deviation valve and distribution manifolds.
- 21 Pre-assembled group MC 5003 designed for heat and sanitary water metering, hydraulic separator and pump
- 22 Mixing group G 1" 1/4 with fixed point for recirculation in solid fuel boilers
- 23 Solid fuel boiler
- 24 Circulation group for solar panels GSP 1180
- 25 Solar panel
- 26 Filter RF 5008
- 27 Sanitary mixing valve VM 660
- 28 Sanitary manifolds

DIMENSIONAL DRAWING

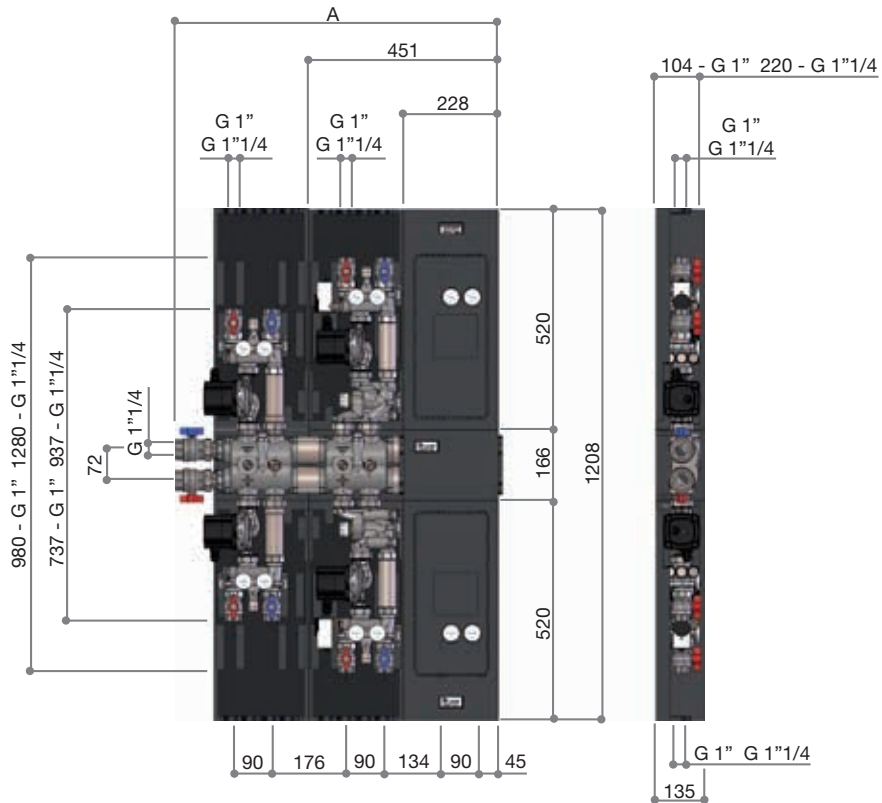
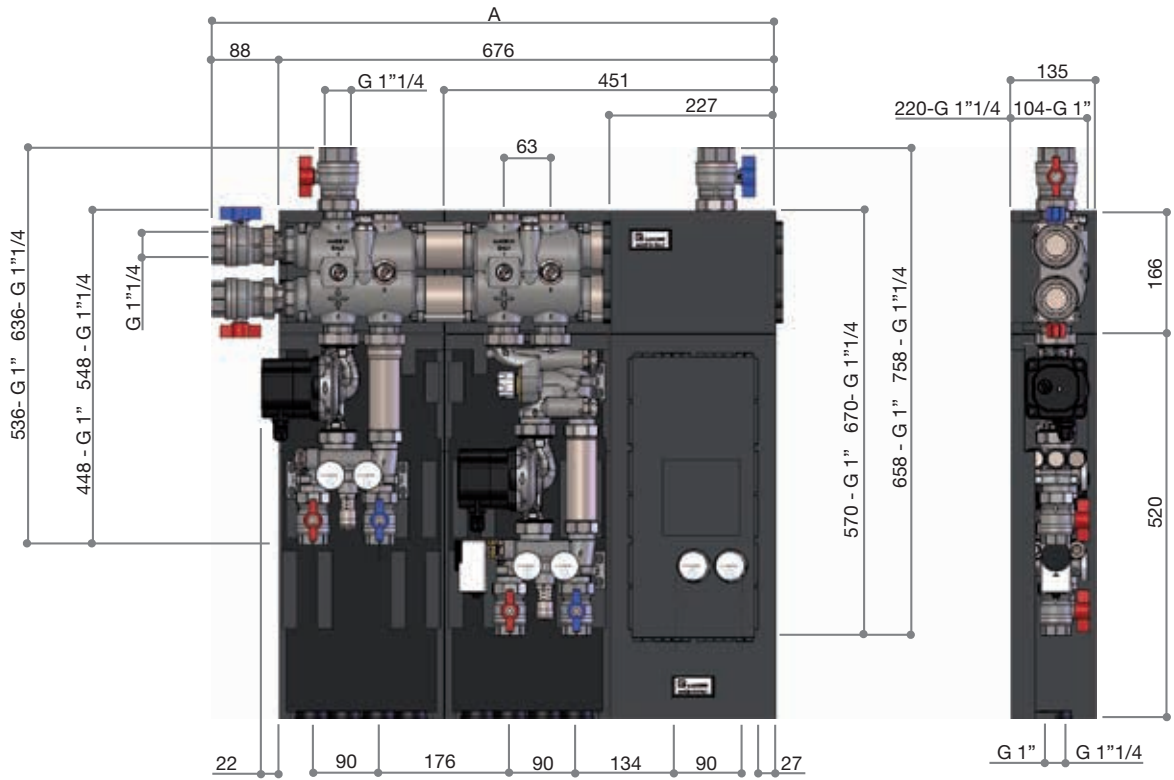

MANIFOLDS

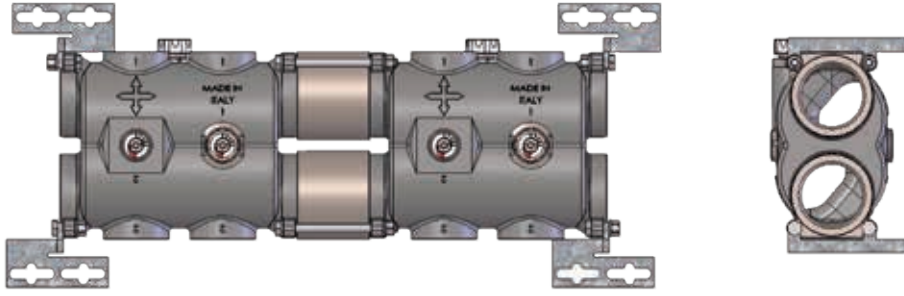

Modular manifold G 1 1/2, with connection for groups G 1 1/4 and balancing and by-pass valves  
It can also act as a hydraulic separator by opening the by-pass installed on all modules.

Free inner passage  $\varnothing$  45mm.  
Connection to primary circuit G 1 1/2.  
Connection to pumping and mixing groups G 1 1/4.

FLOW SCHEME

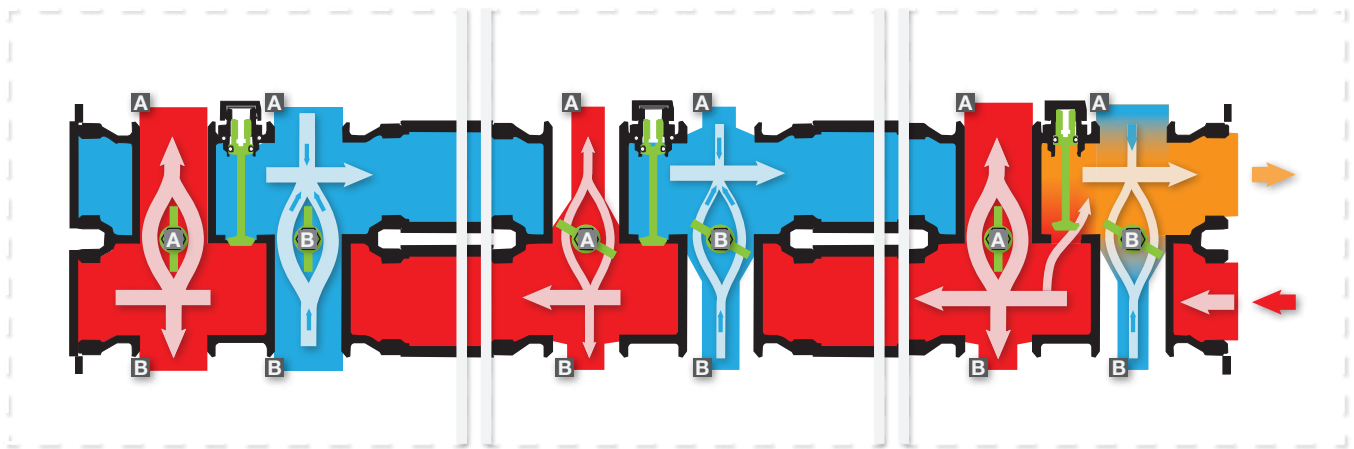

Manifold module with:  
A. Balancing valve all open  
B. Balancing valve all open

Manifold module with:  
A. Balancing valve partially open  
B. Balancing valve partially open

Manifold module with:  
A. Balancing valve all open  
B. Balancing valve partially open

HYDRAULIC CHARACTERISTICS OF MANIFOLD CD 1210

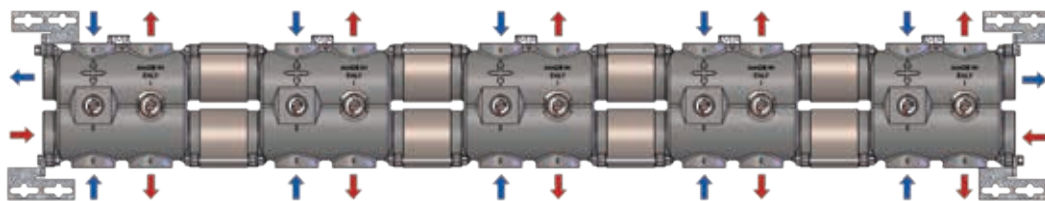

When the manifold CD 1210 is assembled in one direction only with the connections alternating on both sides of the manifold and main connection G 1 1/2, it works like a coplanar manifold.  
If necessary, it can be assembled so as to reverse the outlets. In the following picture the third and fourth module are inverted.

The outlets can be reversed by rotating the module of the manifold of 180°. The head inlets on the manifold and all the modules will remain unchanged. This is very convenient when it is necessary to adjust the manifold connections to the existing installations.

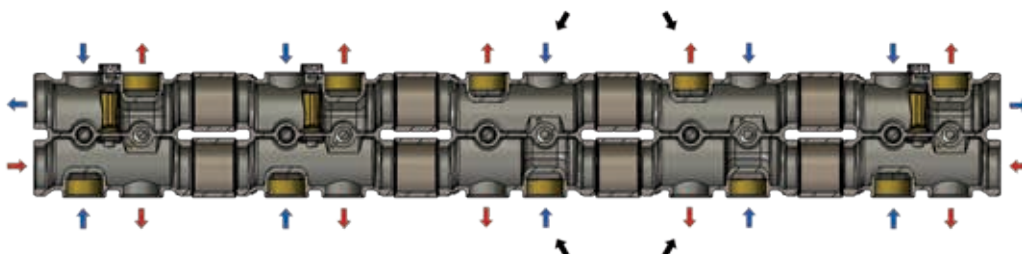

### MANIFOLDS FLOW RATE CHART

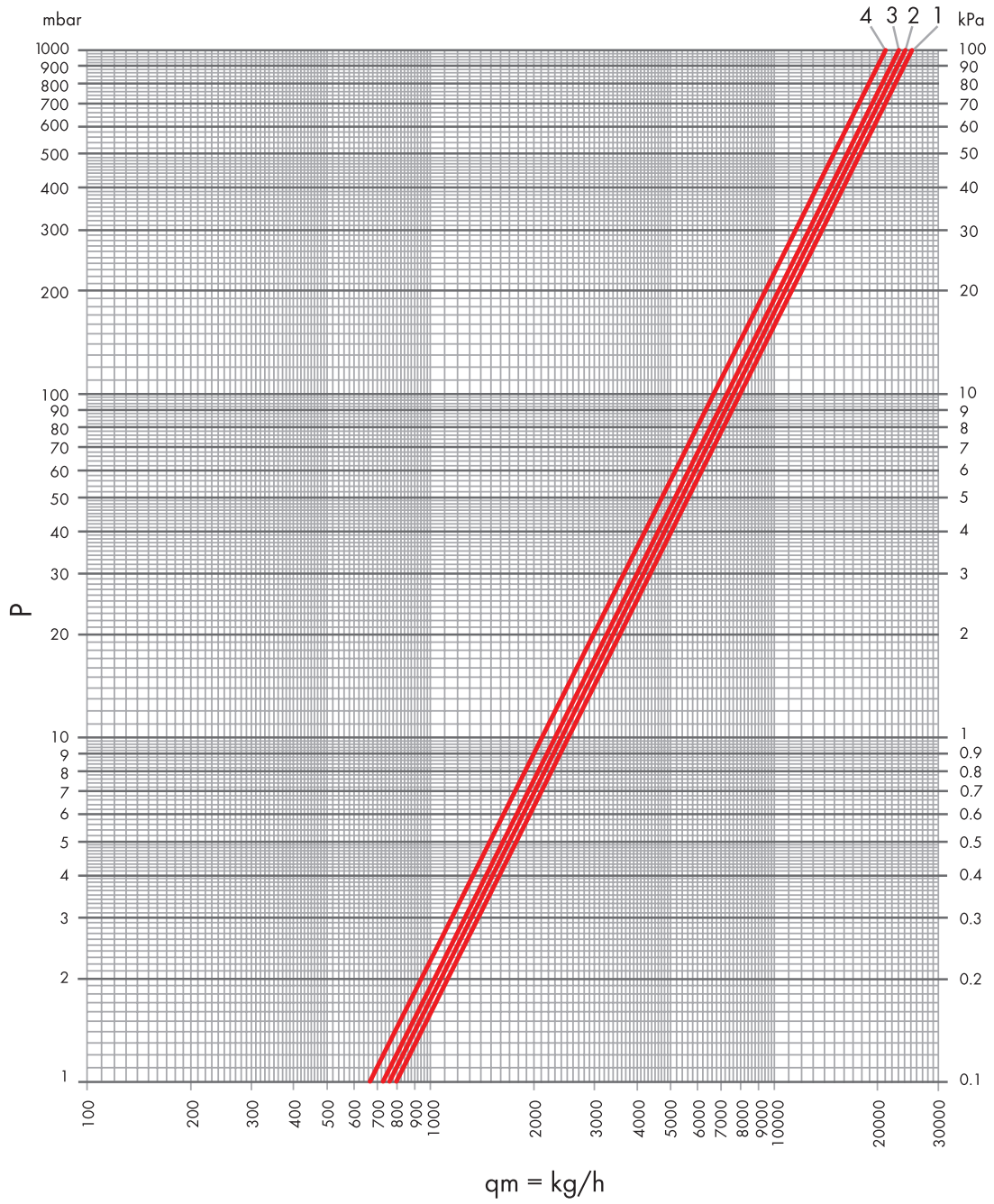

Kvs	OUTLETS N°	POS
25	2	1
24	3	2
23	4	3
21	5	4

## BALANCING VALVE AND BYPASS KV CHART

### BYPASS

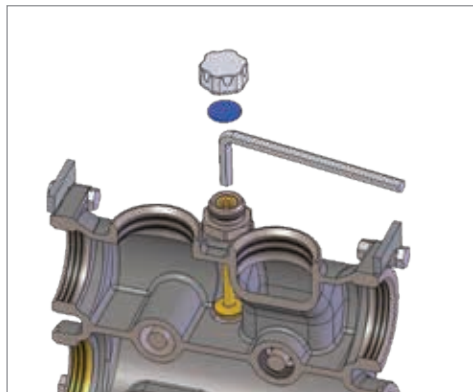

CLOSURE TURNS	Kv
1/4	0,17
1/2	0,51
1	1,27
1"1/2	1,87
2	2,55
2"1/2	3,05

CLOSURE TURNS	Kv
3	3,56
3"1/2	3,82
4	3,99
4"1/2	4,16
All open	4,33

The manifold can function as a hydraulic separator opening the bypass of each module.

It is a useful solution when there is more than one heat generator and/or primary circuit.

### BALANCING VALVE

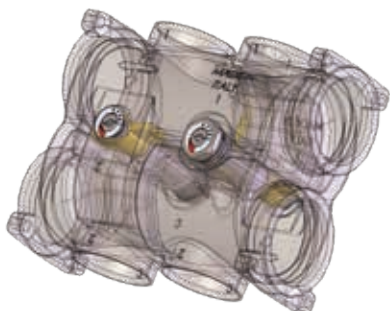

STEM INDEX POSITION	Kv
0	5,43
1	6,79
3	8,13
5	8,51
7	8,72

The regulation of the balancing valve is very handy (and in some cases essential) when a manifold supplies several groups.

The groups are all connected in parallel, when a group is disadvantaged, the balancing valves can correct the situation by balancing the circuits so as to assure the correct functioning of the system.

#### PLEASE NOTE

Each manifold module has two balancing valves. The regulation of the valves can be made on both sides of the manifold.

Each valve regulates the Kv of a couple of connection G 1"1/4. The corresponding valves and connection are identified by the numbers "1" and "2".



MODULAR MANIFOLD DIMENSIONAL DRAWING

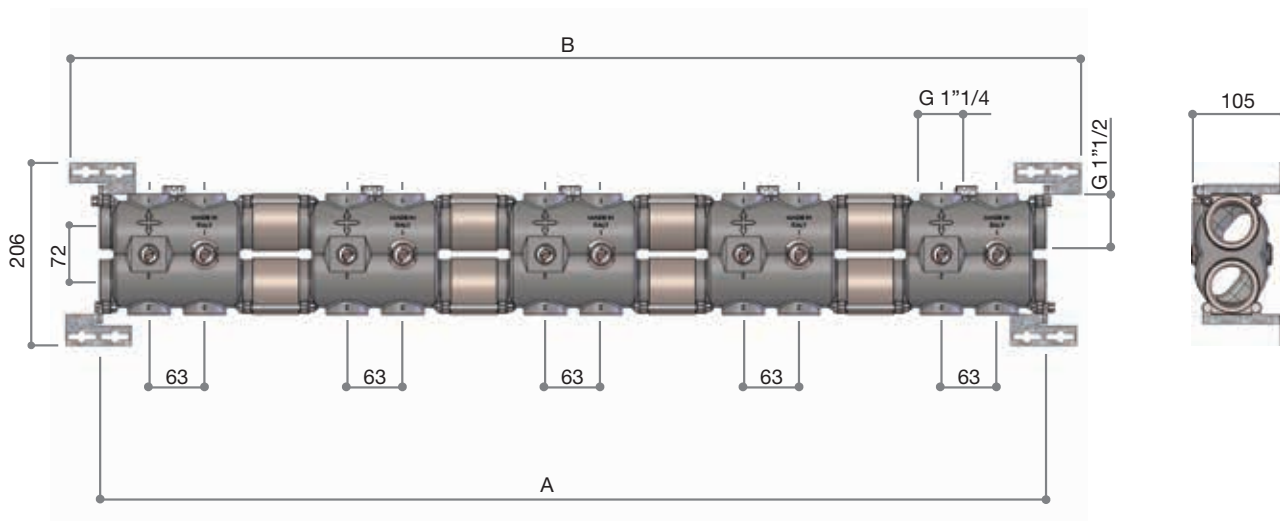

CD 1210

CODE	CONNECTIONS	A	B	C	D	E	F	G	H	L	M	N	P	R
68744251	1+1	174	267	-	-	-	-	-	-	-	-	-	-	-
68744252	2+2	398	471	-	-	-	-	-	-	-	-	-	-	-
68744253	3+3	622	695	-	-	-	-	-	-	-	-	-	-	-
68744254	4+4	846	919	-	-	-	-	-	-	-	-	-	-	-
68744255	5+5	1070	1143	-	-	-	-	-	-	-	-	-	-	-



CD 1210

Modular distribution manifold G 1 1/2 with connection for groups G 1 1/4 and bypass, balancing valves. The bypass valves installed on all the modules can be opened and function as a hydraulic separator. Internal free passage ø 45mm. (the CB version is insulated).

CODE	CONNECTIONS	SIZE	Ⓚg	📦	📦
68744251	1+1	G 1 1/2 x G 1 1/4	3,884	1	-
68744251CB	1+1		3,964	1	-
68744252	2+2		8,226	1	-
68744252CB	2+2		8,386	1	-
68744253	3+3		12,568	1	-
68744253CB	3+3		12,808	1	-
68744254	4+4		16,910	1	-
68744254CB	4+4		17,230	1	-
68744255	5+5		21,252	1	-
68744255CB	5+5		21,652	1	-

## PUMPING GROUPS

### DIMENSIONAL DRAWING

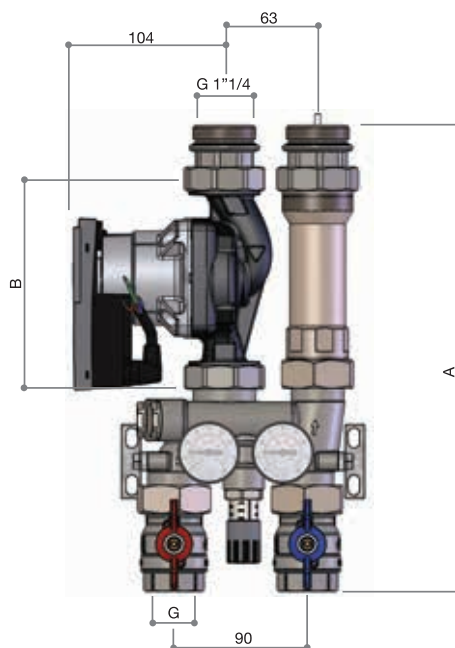
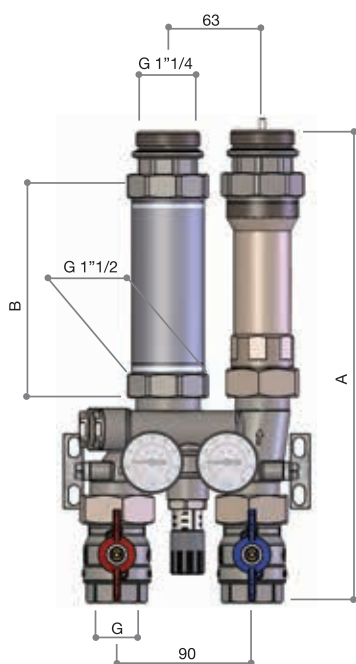

#### GR 1220

CODE	SIZE	A	B	C	D	E	F	G
68763400	G 1"	315	130	-	-	-	-	G 1"
68764200	G 1 1/4"	415	180	-	-	-	-	G 1 1/4"

#### GR 1230

CODE	SIZE	A	B	C	D	E	F	G
68763410	G 1"	315	130	-	-	-	-	G 1"
68764210	G 1 1/4"	415	180	-	-	-	-	G 1 1/4"

### HYDRAULIC SCHEME

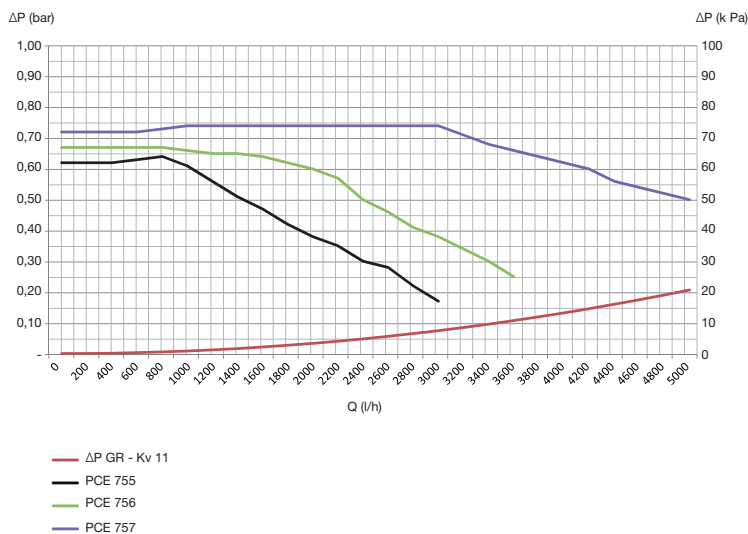
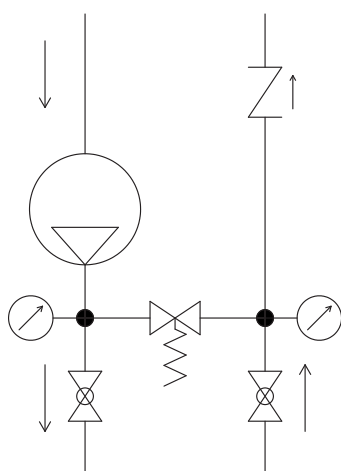

To avoid excessive noise in the system, do not use with  $\Delta P$  value higher than 0,2-0,25 bar.

## PUMPING GROUPS





### GR 1220

Pumping group without pump.  
Maximum recommended flow rate  
3.000 l/h.

Each group is equipped with:

- thermometers to display the delivery and return temperature;
- differential bypass valve;
- check valve;
- shut-off valves for circuits.  
(the CB version is insulated).

CODE	SIZE	INTERAXIS			
68763400	G 1"	130 mm	4,474	1	-
68763400CB	G 1"	130 mm	4,754	1	-
68764201	G 1"	180 mm	4,922	1	-
68764200	G 1"1/4	180 mm	5,474	1	-
68764200CB	G 1"1/4	180 mm	5,754	1	-





### GR 1230

Pumping group with pump.  
Maximum recommended flow rate  
3.000 l/h.

Each group is equipped with:

- thermometers to display the delivery and return temperature;
- differential bypass valve;
- check valve;
- shut-off valves for circuits.  
(the CB version is insulated).

CODE	SIZE	INTERAXIS			
68763410	G 1"	130 mm	5,582	1	-
68763410CB	G 1"	130 mm	5,862	1	-
68764210	G 1"1/4	180 mm	8,092	1	-
68764210CB	G 1"1/4	180 mm	8,372	1	-

## FIXED POINT GROUP

### DIMENSIONAL DRAWING

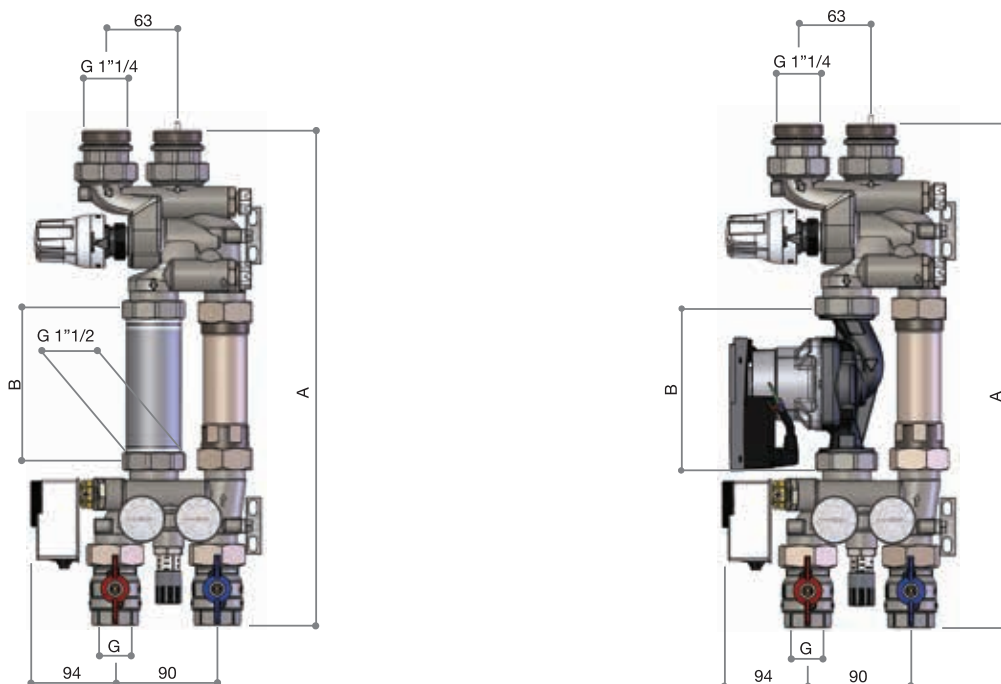

#### GM 1240

CODE	SIZE	A	B	C	D	E	F	G
68763420	G 1"	437	130	-	-	-	-	G 1"
68764220	G 1 1/4"	537	180	-	-	-	-	G 1 1/4"

#### GM 1250

CODE	SIZE	A	B	C	D	E	F	G
68763430	G 1"	437	130	-	-	-	-	G 1"
68764230	G 1 1/4"	537	180	-	-	-	-	G 1 1/4"

### HYDRAULIC SCHEME

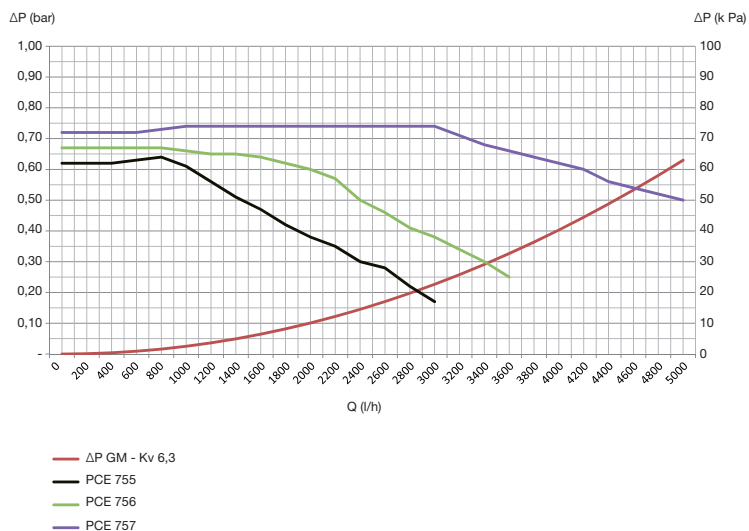
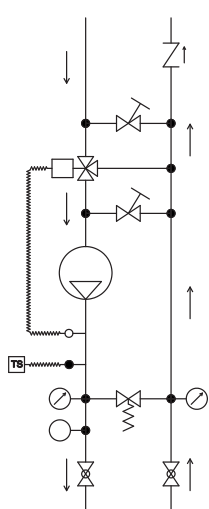

To avoid excessive noise in the system, do not use with  $\Delta P$  value higher than 0,2-0,25 bar.



## FIXED POINT GROUP

**GM 1240**

Fixed-point group without pump.  
Maximum recommended flow rate  
2.750 l/h.

Each group is equipped with:

- 3-way piston mixing valve;
- thermostatic head with regulation for fixed point;
- bypass valves for manual adjustment for the circuits before and after the mixing valve;
- thermometers to display the delivery and return temperature;
- bypass differential valve;
- check valve;
- shut-off valves for circuits.  
(the CB version is insulated).



CODE	SIZE	INTERAXIS			
68763420	G 1"	130 mm	4,946	1	-
68763420CB	G 1"	130 mm	5,226	1	-
68764220	G 1"1/4	180 mm	5,827	1	-
68764220CB	G 1"1/4	180 mm	6,107	1	-

**GM 1250**

Fixed-point group with pump.  
Maximum recommended flow rate  
2.750 l/h.

Each group is equipped with:

- 3-way piston mixing valve;
- thermostatic head with regulation for fixed point;
- bypass valves for manual adjustment for the circuits before and after the mixing valve;
- thermometers to display the delivery and return temperature;
- bypass differential valve;
- check valve;
- shut-off valves for circuits.  
(the CB version is insulated).

CODE	SIZE	INTERAXIS			
68763430	G 1"	130 mm	6,054	1	-
68763430CB	G 1"	130 mm	6,334	1	-
68764230	G 1"1/4	180 mm	8,445	1	-
68764230CB	G 1"1/4	180 mm	8,725	1	-

## SLIDING POINT GROUP

### DIMENSIONAL DRAWING

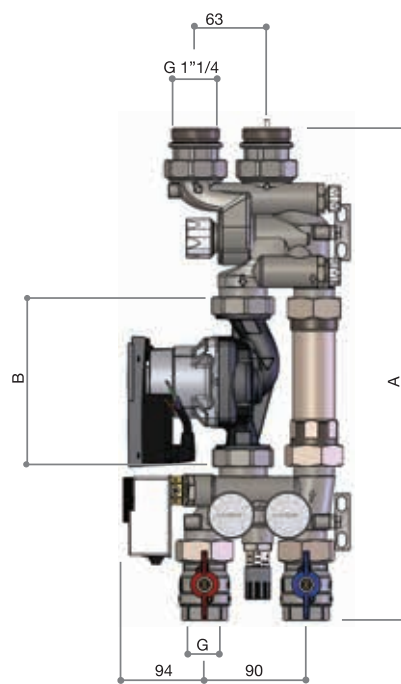
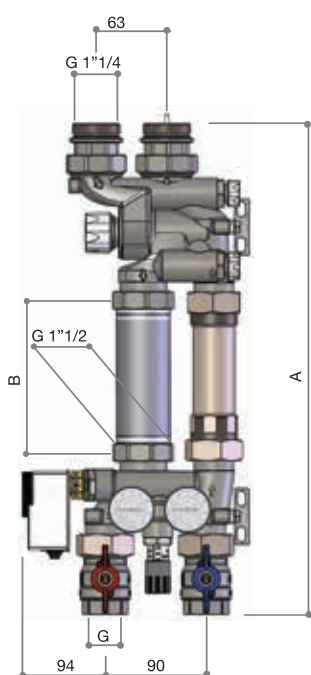

#### GM 1260

CODE	SIZE	A	B	C	D	E	F	G
68763440	G 1"	437	130	-	-	-	-	G 1"
68764240	G 1 1/4"	537	180	-	-	-	-	G 1 1/4"

#### GM 1270

CODE	SIZE	A	B	C	D	E	F	G
68763450	G 1"	437	130	-	-	-	-	G 1"
68764250	G 1 1/4"	537	180	-	-	-	-	G 1 1/4"

### HYDRAULIC SCHEME

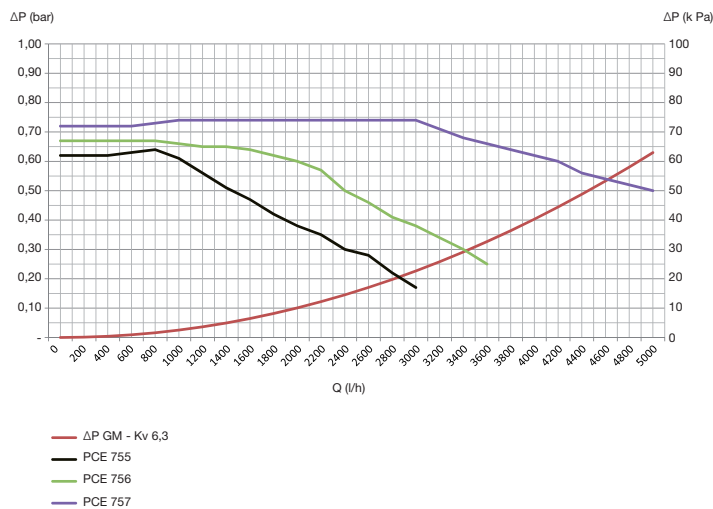
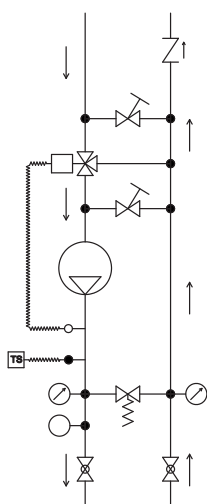

To avoid excessive noise in the system, do not use with  $\Delta P$  value higher than 0,2-0,25 bar.

## SLIDING POINT GROUP



**GM 1260**

Sliding-point group without pump.  
Maximum recommended flow rate 2.750 l/h.

Each group is equipped with:

- 3-way piston mixing valve;
- possibility to install a 3-point or 0-10 V motor on a screw with standard connection M30x1,5 mm;
- bypass valves for manual adjustment for the circuits before and after the mixing valve;
- thermometers to display the delivery and return temperature;
- bypass differential valve;
- check valve;
- shut-off for circuits.

(the CB version is insulated)

CODE	SIZE	INTERAXIS			
68763440	G 1"	130 mm	4,800	1	-
68763440CB	G 1"	130 mm	5,080	1	-
68764241	G 1"	180 mm	5,129	1	-
68764240	G 1"1/4	180 mm	5,681	1	-
68764240CB	G 1"1/4	180 mm	5,961	1	-



**GM 1270**

Sliding-point group with pump.  
Maximum recommended flow rate 2.750 l/h.

Each group is equipped with:

- 3-way piston mixing valve;
- possibility to install a 3-point or 0-10 V motor on a screw with standard connection M30x1,5 mm;
- bypass valves for manual adjustment for the circuits before and after the mixing valve;
- thermometers to display the delivery and return temperature;
- bypass differential valve;
- check valve;
- shut-off for circuits.

(the CB version is insulated)

CODE	SIZE	INTERAXIS			
68763450	G 1"	130 mm	5,908	1	-
68763450CB	G 1"	130 mm	6,188	1	-
68764250	G 1"1/4	180 mm	8,299	1	-
68764250CB	G 1"1/4	180 mm	8,579	1	-

## APPLICATIONS AND ASSEMBLY OPTIONS

### GR 1220 - GR 1230

Can be used to connect an external heating source or as pumping unit.

### GM 1260 - GM 1270

Can be used for sliding point systems.

### GM 1260 - GM 1270

Can be used for sliding point systems.

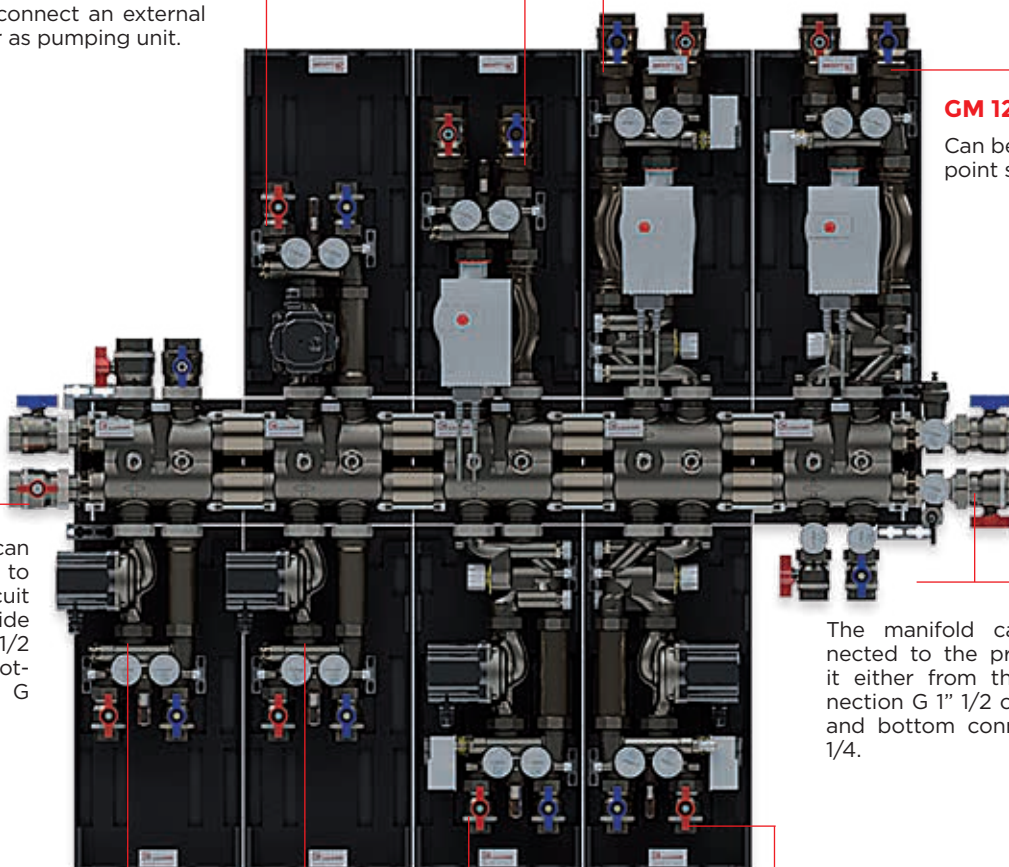

The manifold can be connected to the primary circuit either from the side connection G 1" 1/2 or the top and bottom connection G 1" 1/4.

The manifold can be connected to the primary circuit either from the side connection G 1" 1/2 or by the top and bottom connection G 1" 1/4.

### GR 1220 - GR 1230

Can be used to connect an external heating source or as pumping unit.

### GM 1260 - GM 1270

Can be used for sliding point systems.

It is possible to reverse the position of the pumping unit or the mixing unit by appropriately connecting the manifolds modules.



## MIXING VALVE VM 1200



Mixing valve DN 25. This valve can be combined with the thermostatic head TT 3051 for fixed point systems, or to an actuator with a M30x1,5 thread, closing point 11,5mm and stroke  $\geq 3$ mm.

Two bypasses are installed on the mixing valve:

- Primary bypass. Enables to generate a recirculation for the pump of the primary circuit (ex. boiler pump).
- Secondary bypass. Allows to generate a recirculation for the pump installed on the group, thus balancing the temperature in the panels and developing thermal inertia for the temperature adjustment system.

Connection to the primary circuit G 1"1/2 male.

Connection to the pump with swivel nut G 1"1/2 and connection to the recirculation socket with swivel nut G 1"1/4.

### TECHNICAL DATA

Mixing valve Kvs 5,5 (recirculation) 6,9 (primary exchange)  
Maximum recommended flow rate to mixing valve 2.750 l/h  
( $\Delta p$  0,25bar)

Maximum recommended differential pressure on mixing valve 0,25 bar

### HYDRAULIC DATA

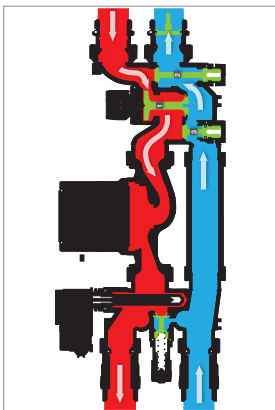

- 1 Mixing valve open
- 2 Primary bypass closed
- 3 Secondary bypass closed

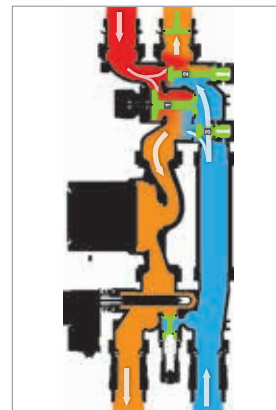

- 1 Mixing valve open
- 2 Primary bypass open
- 3 Secondary bypass open

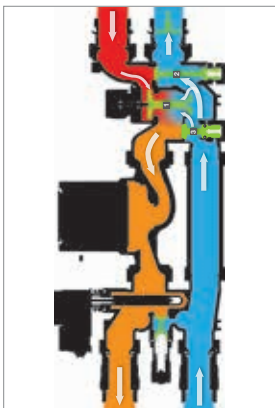

- 1 Mixing valve partially open
- 2 Primary bypass closed
- 3 Secondary bypass closed

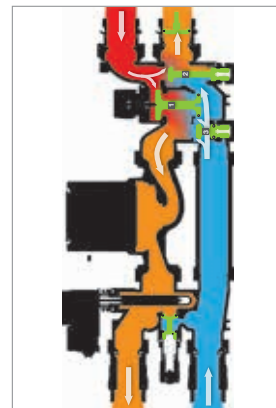

- 1 Mixing valve partially open
- 2 Primary bypass open
- 3 Secondary bypass open

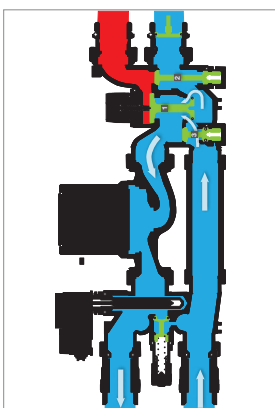

- 1 Mixing valve closed
- 2 Primary bypass closed
- 3 Secondary bypass closed

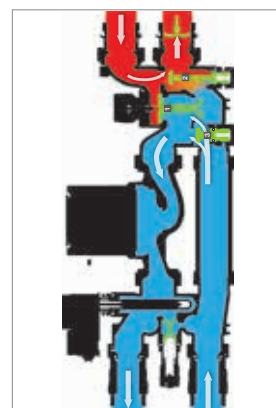

- 1 Mixing valve closed
- 2 Primary bypass open
- 3 Secondary bypass open

CHARACTERISTIC DIAGRAM ACCORDING TO THE STROKE OF THE SCREW

PRIMARY DIAGRAM/RECIRCULATION WITH BYPASS CLOSED

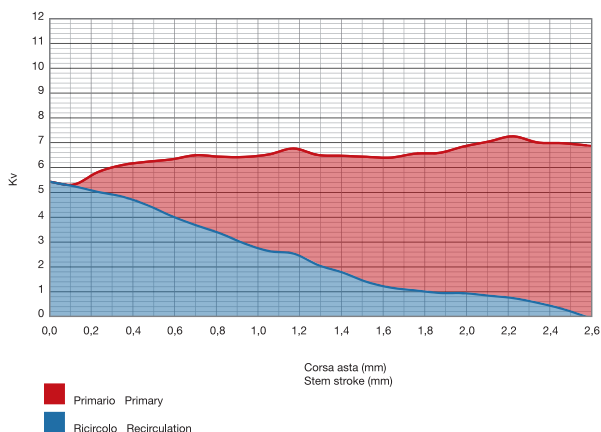

Kv PRIMARY	Kv RECIRCULATION	STEM STROKE	% PRIMARY	% RECIRCULATION
0,00	5,43	closed	0%	100%
0,07	5,25	0,1	1%	99%
0,80	5,02	0,2	14%	86%
1,27	4,83	0,4	21%	79%
1,74	4,49	0,5	28%	72%
2,28	4,05	0,6	36%	64%
2,82	3,68	0,7	43%	57%
3,09	3,35	0,8	48%	52%
3,49	2,94	0,9	54%	46%
3,89	2,64	1,1	60%	40%
4,23	2,54	1,2	62%	38%
4,43	2,08	1,3	68%	32%
4,70	1,78	1,4	73%	27%
5,03	1,40	1,5	78%	22%
5,23	1,17	1,6	82%	18%
5,50	1,06	1,8	84%	16%
5,63	0,96	1,9	85%	15%
5,90	0,95	2,0	86%	14%
6,20	0,85	2,1	88%	12%
6,51	0,75	2,2	90%	10%
6,45	0,56	2,3	92%	8%
6,66	0,32	2,5	95%	5%
6,90	0,00	all open	100%	0%

PRIMARY DIAGRAM/RECIRCULATION WITH BYPASS OPEN

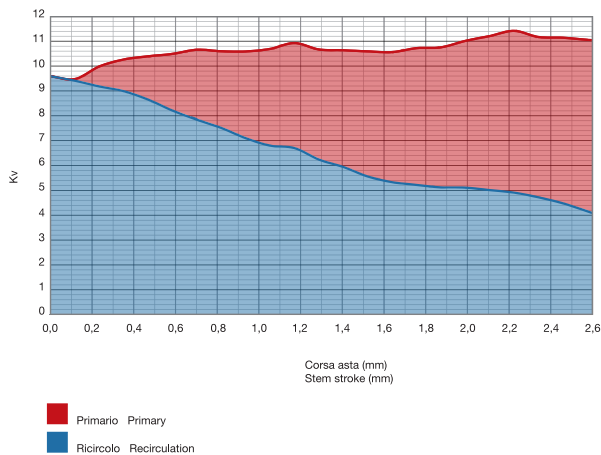

Kv PRIMARY	Kv RECIRCULATION	STEM STROKE	% PRIMARY	% RECIRCULATION
0,00	9,59	closed	0%	100%
0,07	9,41	0,1	1%	99%
0,80	9,18	0,2	8%	92%
1,27	8,99	0,4	12%	88%
1,74	8,65	0,5	17%	83%
2,28	8,21	0,6	22%	78%
2,82	7,84	0,7	26%	74%
3,09	7,51	0,8	29%	71%
3,49	7,10	0,9	33%	67%
3,89	6,80	1,1	36%	64%
4,23	6,70	1,2	39%	61%
4,43	6,24	1,3	42%	58%
4,70	5,94	1,4	44%	56%
5,03	5,56	1,5	48%	52%
5,23	5,33	1,6	50%	50%
5,50	5,22	1,8	51%	49%
5,63	5,12	1,9	52%	48%
5,90	5,11	2,0	54%	46%
6,20	5,01	2,1	55%	45%
6,51	4,91	2,2	57%	43%
6,45	4,72	2,3	58%	42%
6,66	4,48	2,5	60%	40%
6,90	4,16	all open	62%	38%

BYPASS AND MIXING KV VALUE ACCORDING TO THE OBTURATOR TURNS

PRIMARY BYPASS		SECONDARY BYPASS	
CLOSURE TURNS	Kv	CLOSURE TURNS	Kv
1/4	0,30	1/4	0,25
1/2	0,64	1/2	0,59
1	1,32	1	1,27
1 1/2	2,04	1 1/2	1,87
2	2,72	2	2,38
2 1/2	3,48	2 1/2	2,97
3	4,07	3	3,22
3 1/2	4,33	3 1/2	3,56
4	4,58	4	3,73
4 1/2	4,67	4 1/2	3,82
all open	4,67	all open	4,16

## ACCESSORIES FOR DISTRIBUTION MANIFOLDS

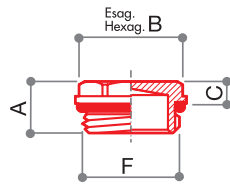

**TC 460**  
End cap with o-ring.

CODE	SIZE	FINISHING	A	B	C	D	E	F	G	H	L			
68559942N	G 1" 1/4	NICKEL-PLATED	25	38	12	-	-	G 1" 1/4	-	-	-	94	30	240
68559948N	G 1" 1/2	NICKEL-PLATED	26	48	16	-	-	G 1" 1/2	-	-	-	160	16	128

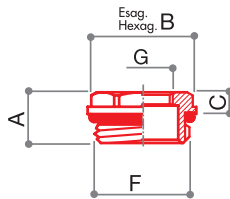

**TC 462**  
Cap with adapter and o-ring.

CODE	SIZE	FINISHING	A	B	C	D	E	F	G	H	L			
68559916N	G 1" 1/2 x G 1"	NICKEL-PLATED	26	48	16	-	-	G 1" 1/2	G 1"	-	-	200	16	128
68559915N	G 1" 1/2 x G 1" 1/4	NICKEL-PLATED	26	48	16	-	-	G 1" 1/2	G 1" 1/4	-	-	124	16	128

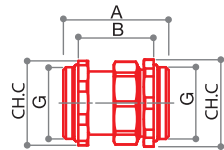

**RD 455**  
Three pieces M-M union fitting with o-ring.

CODE	SIZE	A	B	C	D	E	F	G	H	L			
68994801N	G 1" 1/2	70	50	65	-	-	-	G 1" 1/2	-	-	460	5	40

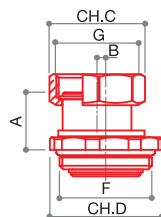

**RE 447**  
Eccentric fitting to assemble groups on manifold CD1210, on the boiler connections side. To be used in pairs.

CODE	SIZE	A	B	C	D	E	F	G	H	L			
68994810N	G 1" 1/2 M x G 1" 1/4 F	30	4,5	46	56	-	G 1" 1/2	G 1" 1/4	-	-	340	5	40

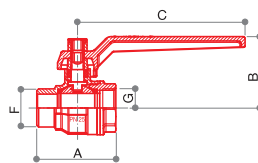

**VC 476**

Nickel-plated full flow ball valve, without pipe union, with blue or red lever.

CODE	SIZE	A	B	C	D	E	F	G	H	L			
68559829B	G 1"1/2	91	75	150	-	-	G 1"1/2	G 1"1/2	-	-	1400	2	16
68559829R	G 1"1/2	91	75	150	-	-	G 1"1/2	G 1"1/2	-	-	1400	2	16

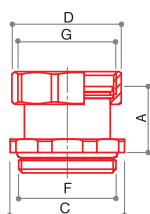

**CR 496**

Nickel plated nut and fitting with gasket for ball valve VC476 connection.

CODE	SIZE	A	B	C	D	E	F	G	H	L			
67934800	G 1"1/2	32	-	56	52	-	G 1"1/2	G 1"1/2	-	-	280	6	48

**INSULATION**



**CB 1220**

Insulation for manifold module CD 1210.

CODE	SIZE	A	B	C	D	E	F	G	H	L			
72000080	G 1"1/4 x G 1"	243	166	138	223	10	135	-	-	-	80	-	1

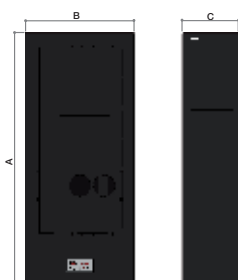

**CB 1222**

Insulation for pumping and mixing groups.

CODE	SIZE	A	B	C	D	E	F	G	H	L			
Pumping groups													
72000082	G 1" - 130 mm	520	223	135	-	-	-	-	-	-	280	-	1
72000084	G 1"1/4 - 180 mm	520	223	135	-	-	-	-	-	-	280	-	1
Mixing groups													
72000086	G 1" - 130 mm	520	223	135	-	-	-	-	-	-	280	-	1
72000088	G 1"1/4 - 180 mm	520	223	135	-	-	-	-	-	-	280	-	1



## GENERAL CONDITIONS OF SALE

**1 PREMISES - 1.1** The present conditions of sale apply to all supplies of Luxor Spa Products (hereafter "Luxor"). Any general conditions, and in particular the conditions of purchase of the Buyer (hereafter "Customer"), unless expressly accepted in writing by Luxor, shall not bind the latter nor exempt the Customer from the application of the present General Conditions (hereafter GSC)

**2. ORDERS - 2.1** The Purchase Orders (referred to as 'Orders') are an irrevocable purchase proposal. By placing an Order, customers fully accept the present General Conditions of Sale.

**2.2** Orders are considered accepted only after Luxor confirms them in writing. The Order confirmation and/or Invoice issued by Luxor will be considered as confirmation.

**2.3** Any changes to the Order requested by the Customer after the sending of the Order Confirmation will only be valid and enforceable after written acceptance by Luxor. Cancellation or modification of Orders without the prior written consent of Luxor, will give Luxor the right to act to obtain reimbursement of the costs incurred, without prejudice to the right to compensation for greater damages.

**3 PRICES - 3.1** Luxor products will be invoiced based on the current price list at the time the order is accepted. Prices do not include VAT or any other taxes.

**3.2** Prices listed in sales catalogues/lists are merely indicative and may be subject to change due to production cost increases. In such cases, Luxor will inform the purchaser of the price increase and provide the reasons.

**4 DELIVERY TERMS - 4.1** The supplies in each individual Order will be delivered within the stated terms in the Order Confirmation.

**4.2** Luxor will not be held responsible for delays in delivery that are not caused by Luxor, such as delays by third parties, including suppliers and sub-suppliers, shippers, and causes of force majeure that result in total or partial inactivity of the plants. In the cases mentioned above, the Customer cannot refuse delivery of the goods, even if it is only partial, nor can they use a delay in delivery as a reason to terminate the contract or claim damages.

**5 SHIPMENTS - 5.1** The products will be delivered to the 'Assigned Port' (Incoterms 2020 EXW), with transport costs and risks borne by the buyer, unless otherwise agreed.

**5.2** Even in the case of agreed delivery in "Free Port" (Incoterms 2020 DDP) with costs borne by Luxor, the goods will still travel at the buyer's risk. Regardless of the delivery terms agreed upon by the parties, the risks will pass to the buyer at the latest with delivery to the first carrier.

**5.3** The transfer of ownership of the goods is suspended until the full price has been paid, but this does not affect the transfer of risk to the purchaser.

**5.4** If special packaging is required, an additional charge as indicated in the price list or order confirmation will be added to the invoice.

**6 PAYMENTS - 6.1** Payments are due as per the terms and manner specified in the order confirmation and/or invoice.

**6.2** Unless otherwise expressly agreed, payments must be made to the bank details mentioned in the sales invoice. For payments made from abroad via bank transfer, the OUR option must be selected to ensure that Luxor receives the net amount on the invoice after deducting bank charges and expenses. Luxor does not authorize any third parties, including agents and representatives, to collect money on its behalf.

**6.3** The Customer is not permitted to suspend or delay payments, even in the event of claims or complaints of defects, and must adhere to the agreed terms.

**6.4** In case of payment interruption or suspension, the Customer will be considered in default. Luxor reserves the right to charge expenses and interest as per Art. 5 and 6 of D.Lgs n. 192/2012, without prejudice to the right to terminate the contract. Delayed payment may also result in Luxor excluding the guarantee for the entire period of delay.

**6.5** If the Customer fails to adhere to the agreed payment terms, or interrupts or suspends payment, Luxor reserves the right to suspend any ongoing supplies and/or make the execution of the current order conditional on the payment of the outstanding debt. Luxor may also withdraw from any further contracts with the Customer and cancel any previously granted favourable conditions, such as discounts or free gifts.

**6.6** The Customer is not permitted to offset any claims they may have against Luxor with debts they owe to Luxor, unless formally authorised by Luxor

**7 EXPRESS TERMINATION CLAUSE - 7.1** Luxor may terminate the contract immediately if the Customer is undergoing bankruptcy or liquidation proceedings, as well as in the event that the Customer is subject to execution proceedings and/or protests and the economic conditions suggest the purchaser is insolvent.

**8 WARRANTY - 8.1** Luxor guarantees the conformity of the products supplied, free from defects that could make them unsuitable for their intended use. The guarantee may be invoked if the defect is due to

manufacturing errors or defects in raw materials that are the responsibility of Luxor.

**8.2** Unless otherwise expressly agreed, the guarantee lasts for one (1) year from the date of delivery. The Customer must make a written complaint within eight (8) days from delivery in the case of apparent defects, or, in the case of hidden defects, from the time of discovery and in any event not later than twelve (12) months from delivery.

**8.3** In the event of non-conforming products, Luxor may, at its discretion, provide the Buyer with replacement products of the same type and quantity free of charge ex works, after verifying the returned products. Any return must always be previously agreed and authorised by Luxor. The goods in question must be returned 'carriage paid' along with a note explaining the reason for the return within 30 days of Luxor's approval. Failure to do so will result in the authorization becoming invalid.

**8.4** If Luxor does not recognize the defective products upon verification, it will invoice those sent as replacements. If Luxor does not recognize the defective products upon verification, they will invoice the replacements. If Luxor is unable to replace defective products, they may issue a credit note to the customer for the value of the defective products. This does not imply any responsibility on Luxor for direct, indirect, or consequential damages resulting from or connected to the defects or faults of the products.

**8.5** It is important to note that this guarantee does not cover instances where the product has been installed, used or maintained in a manner that is contrary to the instructions and warnings provided in the installation, use, and maintenance manuals that were included with the product. Additionally, any installation or repair work should only be carried out by qualified personnel.

**8.6** The guarantee will not apply if the Purchaser breaches their contractual obligations.

**8.7** This warranty is the only warranty and replaces any other written, oral or implied warranties. By accepting these General Terms and Conditions, the Purchaser expressly waives any right of recourse arising from the sale and/or installation of the Products to a non-professional consumer.

**9. RESERVATION OF PROPERTY 9.1** The sale of Luxor S.p. A's Products is carried out under reservation of ownership. Therefore the products will remain the property of Luxor S.p.A. until the full payment of the price by the buyer.

**10 TRANSFER OF THE CONTRACT 10.1** It is forbidden to transfer the Contract and/or any interest, right and obligation connected to it to third parties without specific written approval by Luxor.

**11 PRIVACY - 11.1** The Customer confirms that they have read the information regarding the processing of their personal data, as required by Articles 13 and 14 of Regulation (EU) 2016/679 (GDPR) as amended. The information can be found at <https://luxor.it/privacy-policy>. By accepting these GTC, the Customer consents to the processing of their personal data.

**11.2** Luxor will process the personal data provided by the Customer, including through external parties, to fulfil legal obligations and carry out administrative and commercial tasks related to the contractual relationship.

**12 APPLICABLE LAW AND COURT OF JURISDICTION - 12.1** Contract is governed by Italian law. Anything not expressly governed by these GVCs shall be governed by the rules on sale provided for in articles 1470 et seq. of the Italian Civil Code.

**12.2** The Parties expressly exclude the application of the Vienna Convention on Contracts for the International Sale of Goods. Any disputes related to the Contract, including those regarding its validity, interpretation, execution, and termination, must be referred exclusively to the Court of Brescia.

**12.3** Luxor reserves the right to take legal action at the competent court of the Customer's location to recover any outstanding debts. The local law will apply in this case.

**13 FINAL CLAUSES - 13.1** The possible nullity and/or ineffectiveness of one or more provisions of these GTC shall not affect the validity of the Contract as a whole.

**13.2** Any amendment to the Contract shall be valid only if made in writing and signed by authorised representatives of both Parties.

The customer acknowledges that they are not a 'consumer' and therefore the provisions of law relating to relations between entrepreneurs and consumers do not apply. The customer declares that they have paid particular attention to the following clauses: Introduction (1.1), Orders (2.1-2.3), Prices (3.2), Delivery Terms (4.1-4.2), Shipping (5.1-5.3), and 6. The following sections require approval: Payments (6.2 - 6.3 - 6.4 - 6.5 - 6.6); 7 Express Termination Clause (7.1); 8 Warranty (8.1 - 8.2 - 8.3 - 8.4 - 8.5 - 8.6 - 8.7); 9. Retention of Title (9.1); 10. Applicable Law and Jurisdiction (12.1 - 12.2 - 12.3); 13 Final Clauses (13.1 - 13.2), and they are to be specifically approved.

These general terms and conditions are published on LUXOR's website (<https://luxor.it/>) where they may be consulted, thereby taking full and proper cognisance thereof, pursuant to and for the purposes of Articles 1341 and 1342 of the Civil Code.