



60 YEARS OF ITALIAN TRADITION

Luxor is an important industrial reality, world wide and European market leader in the production of flexible hoses and components for hydro and thermo-sanitary installations. Luxor has been the expression of the most prestigious made in Italy and the great Italian high technology mechanical workings tradition for fifty years; a quality certified and recognized by the most prestigious International Certification Institutes all over the world.

Our mission is the complete customer satisfaction through a process of continuous technological research in order to make high quality, reliable products, anticipating the market evolutions by innovative partnership with both customers and suppliers. Luxor mission takes

place in its own Research and Development Centre in which new and advanced technologies are constantly analyzed and researched with continuous investments to offer the most innovative and reliable solutions for the international markets at competitive costs, ensuring strict quality controls on each single piece.

Luxor entirely plans and realizes each product, thanks to its decennial know how. The great production strength, a "slender" innovative and advanced industrial organization together with a modern logistic conception, make Luxor able to satisfy every kind of request, even customized, with fast deliveries all over the world.



Luxor is certified ISO 9001:2015 by DEKRA Group certification body

CERTIFICATION



Please contact our offices for information about technical specifications and certified products or visit the website of the corresponding certification body for the latter.

Please refer to www.nsf.org for a complete list of NSF approved products.
Please refer to www.iapmort.org for a complete list of UPC/CUPC approved products.



LUXOR®

RADIATOR VALVES

1.2 / THERMOTEKNA

THERMOTEKNA

THERMOSTATIC VALVE BODIES WITH PRE-REGULATION



* UNI EN 215
Approved

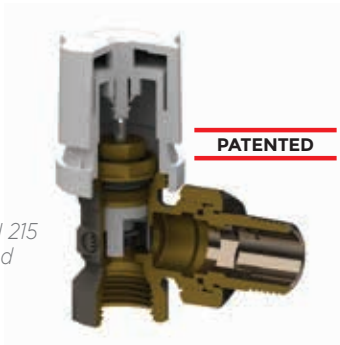

**REVERSE
FLOW**



The screw of ThermoTekna valves allows to preset the flow thanks to a shaped acetal ring. The thermostatic screw enables to replace one of the o-rings on the control stem without draining the system. The valves - where clearly indicated - are approved according to UNI EN 215. The valves are nickel plated. Valves and lockshields must be opened with a differential pressure lower than 1 bar.

The tightness of Tekna lockshields is ensured by an o-ring on the obturator and, if necessary, by a further o-ring between the body and the plug. When in closed position, the tightness is granted by an o-ring and a conical metal collar. The lockshields are nickel plated. The flow can be adjusted by limiting the lift of the obturator.

TECHNICAL DATA



DN

10
15
20



Max temperature

120 °C



Max pressure

10 bar



Max differential pressure
(thermostatic valves)

0,6 bar



Max differential pressure

1 bar



Materials

CW617N
UNI EN
12165:2016



Knob

white ABS
RAL 9016



Stem

AISI 316



Testing

100%

SYSTEM CONNECTIONS



Iron pipe

G 3/8
G 1/2
G 3/4

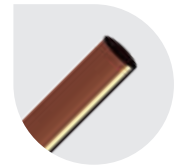

Copper pipe

W 24x19 - TR 91
G 3/4 EK - TR 91/A



Plastic pipe

W 24x19 - TP 95
G 3/4 EK - TP 98



Multilayer pipe

W 24x19 - TP 97
G 3/4 EK - TP 99

RADIATOR CONNECTION



conical milled thread

G 3/8
G 1/2
G 3/4



cylindrical thread with soft sealing

G 3/8
G 1/2
G 3/4

All valves and lockshields are 100% checked with an electronically controlled pneumatic test.

The characteristics of the fluid in the system must be compliant with the UNI 8065: 2019 directive.

FLOW ADJUSTMENT AND REVERSE FLOW

To adjust the maximum flow rate, proceed as follows:

- align the reference mark on the stainless steel stem with one of the positions marked on the valve.

Luxor thermostatic valves are now EN 215 approved in reverse flow mode as well.

This characteristic allows for installation on the inlet as well as on the outlet of the radiator up to a 0,6 bar differential pressure.

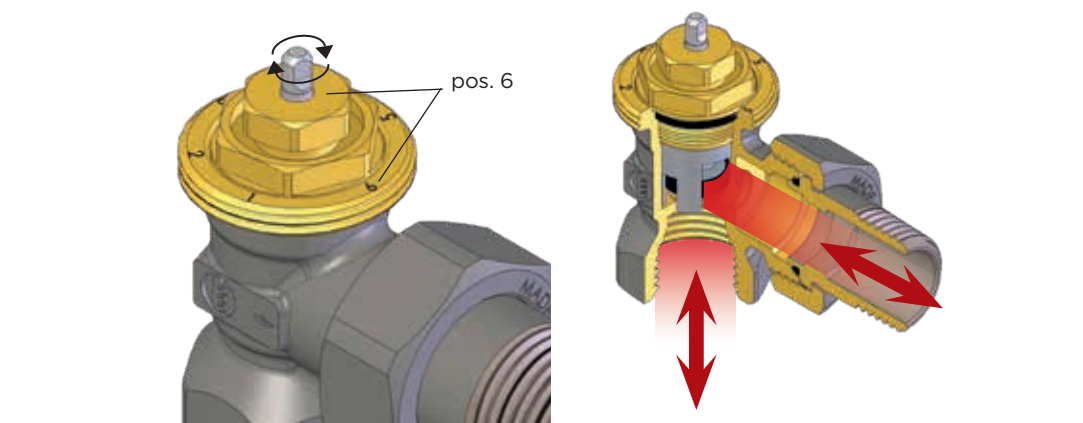
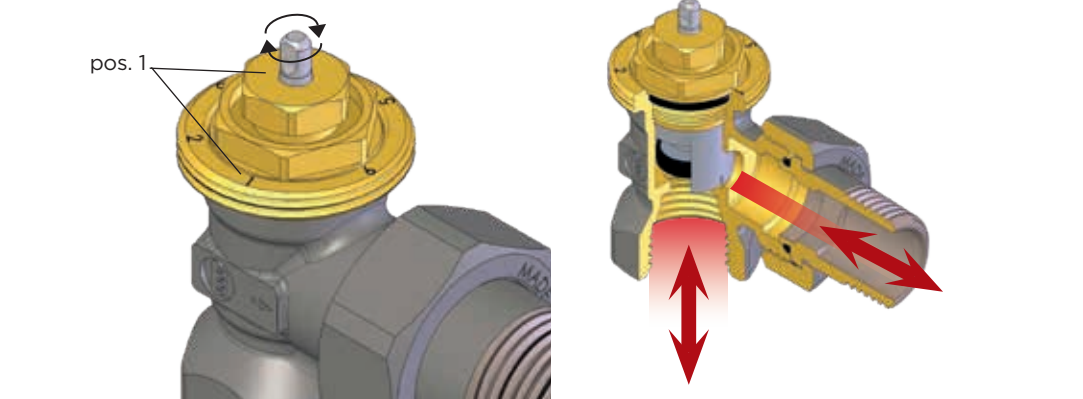

TIGHTNESS ON THE STEM

The tightening system can be easily replaced without draining the system:

- unscrew the hexagonal collar with a 13 mm wrench key;
- remove the o-ring "art. 582 - code 3424602", clean the stainless steel stem, insert a new o-ring "art. 582";
- assemble the collar screwing tight.









THERMOSTATIC KIT: CONNECTION FOR IRON PIPE



 * UNI EN 215
Approved

KT 202







Complete thermostatic kit for radiator connection. Equipped with RS 202 + DS 22 + TT 3000. Connection for iron pipe.

CODE	SIZE						
12821700	DN 10 3/8	-	-	-	436	1	32
12822100*	DN 15 1/2	TR 92	-	TP 90	521	1	32
12822700	DN 20 3/4	-	-	-	671	1	32



KT 201

Complete thermostatic kit for radiator connection. Equipped with RD 201 + DD 21 + TT 3000. Connection for iron pipe.







CODE	SIZE						
12901700	DN 10 3/8	-	-	-	473	1	32
12902100	DN 15 1/2	TR 92	-	TP 90	514	1	32
12902700	DN 20 3/4	-	-	-	685	1	32



 * UNI EN 215
Approved

KT 206







Complete thermostatic kit for radiator connection. Equipped with RS 206 + DS 26 + TT 3000. Connection for iron pipe.

CODE	SIZE						
12822117	DN 10 3/8	-	-	-	426	1	32
12822103*	DN 15 1/2	TR 92	-	TP 90	501	1	32
12822703	DN 20 3/4	-	-	-	636	1	32



KT 205

Complete thermostatic kit for radiator connection. Equipped with RD 205 + DD 25 + TT 3000. Connection for iron pipe.

CODE	SIZE						
12942117	DN 10 3/8	-	-	-	471	1	32
12942103	DN 15 1/2	TR 92	-	TP 90	536	1	32
12942703	DN 20 3/4	-	-	-	706	1	32







THERMOSTATIC KIT: CONNECTION FOR COPPER AND PLASTIC PIPE W24X19



KT 212





Complete thermostatic kit for radiator connection. Equipped with RS 212 + DS 32 + TT 3000. Connection for copper and plastic pipe.

CODE	SIZE						
12841700*	DN 10 3/8	TR 91	TP 95	TP 97	424	1	32
12842100*	DN 15 1/2	TR 91	TP 95	TP 97	477	1	32



KT 211







Complete thermostatic kit for radiator connection. Equipped with RD 211 + DD 31 + TT 3000. Connection for copper and plastic pipe.

CODE	SIZE						
12861700	DN 10 3/8	TR 91	TP 95	TP 97	445	1	32
12862100	DN 15 1/2	TR 91	TP 95	TP 97	492	1	32



KT 209







Complete thermostatic kit for radiator connection. Equipped with RS 209 + DS 39 + TT 3000. Connection for copper and plastic pipe.

CODE	SIZE						
12842117*	DN 10 3/8	TR 91	TP 95	TP 97	441	1	32
12842103*	DN 15 1/2	TR 91	TP 95	TP 97	484	1	32



KT 208

Complete thermostatic kit for radiator connection. Equipped with RD 208 + DD 38 + TT 3000. Connection for copper and plastic pipe.

CODE	SIZE						
12962117	DN 10 3/8	TR 91	TP 95	TP 97	348	1	32
12962103	DN 15 1/2	TR 91	TP 95	TP 97	381	1	32



Fittings for copper pipe



Fittings for plastic pipe



Fittings for multilayer pipe



Fittings: chapter 7



Accessories: chapter 1.A







THERMOSTATIC KIT: CONNECTION FOR COPPER AND PLASTIC PIPE G3/4 EUROKONUS



* UNI EN 215
Approved

KT 212/A







Complete thermostatic kit for radiator connection. Equipped with RS 212/A + DS 32/A + TT 3000. Eurokonus connection.

CODE	SIZE						
12842718*	DN 10 3/8	TR 91/A	TP 98	TP 99	406	1	32
12842721*	DN 15 1/2	TR 91/A	TP 98	TP 99	483	1	32



KT 211/A

Complete thermostatic kit for radiator connection. Equipped with RD 211/A + DD 31/A + TT 3000. Eurokonus connection.







CODE	SIZE						
12862719	DN 10 3/8	TR 91/A	TP 98	TP 99	440	1	32
12862722	DN 15 1/2	TR 91/A	TP 98	TP 99	484	1	32



* UNI EN 215
Approved

KT 209/A







Complete thermostatic kit for radiator connection. Equipped with RS 209/A + DS 39/A + TT 3000. Eurokonus connection.

CODE	SIZE						
12842717*	DN 10 3/8	TR 91/A	TP 98	TP 99	447	1	32
12842703*	DN 15 1/2	TR 91/A	TP 98	TP 99	484	1	32



KT 208/A

Complete thermostatic kit for radiator connection. Equipped with RD 208/A + DD 38/A + TT 3000. Eurokonus connection.

CODE	SIZE						
12962717	DN 10 3/8	TR 91/A	TP 98	TP 99	340	1	32
12962703	DN 15 1/2	TR 91/A	TP 98	TP 99	380	1	32



CONNECTION FOR IRON PIPE

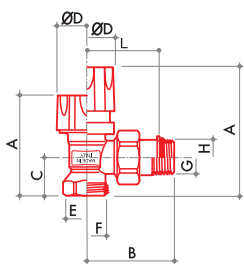

RS 202

Angle radiator valve, thermostatically or electronically controlled with protection cap. Connection for iron pipe.



Fittings



** Only for the sizes indicated

CODE	SIZE	A	B	C	D	E	F	G	H	L			
12021700	DN 10 3/8	58	50	20	37	G 3/8	-	R 3/8	-	-	156	10	80
12022100*	DN 15 1/2**	60	53	23	37	G 1/2	-	R 1/2	-	-	198	10	80
12022700	DN 20 3/4	60	62	27	37	G 3/4	-	R 3/4	-	-	264	8	64

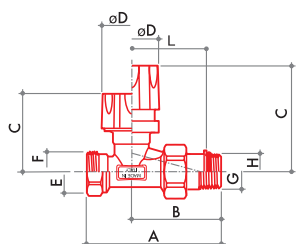

RD 201

Straight radiator valve, thermostatically or electronically controlled with protection cap. Connection for iron pipe.

Fittings



** Only for the sizes indicated

CODE	SIZE	A	B	C	D	E	F	G	H	L			
12221700	DN 10 3/8	76	51	46	37	G 3/8	-	R 3/8	-	-	177	10	80
12222100	DN 15 1/2**	83	55	46	37	G 1/2	-	R 1/2	-	-	216	10	80
12222700	DN 20 3/4	97	65	47	37	G 3/4	-	R 3/4	-	-	301	8	64

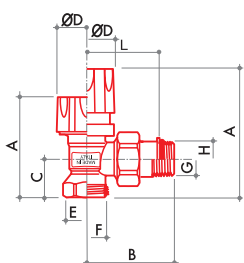

RS 206

Angle radiator valve, thermostatically or electronically controlled with protection cap. Connection for iron pipe.



Fittings



** Only for the sizes indicated

CODE	SIZE	A	B	C	D	E	F	G	H	L			
12022117	DN 10 3/8	58	47	20	37	G 3/8	-	-	G 3/8	37	164	10	80
12022103*	DN 15 1/2**	61	49	23	37	G 1/2	-	-	G 1/2	39	202	10	80
12022703	DN 20 3/4	60	60	27	37	G 3/4	-	-	G 3/4	48	267	8	64

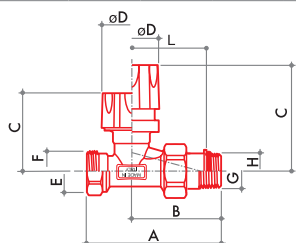

RD 205

Straight radiator valve, thermostatically or electronically controlled with protection cap. Connection for iron pipe.

Fittings



** Only for the sizes indicated

CODE	SIZE	A	B	C	D	E	F	G	H	L			
12222117	DN 10 3/8	73	48	46	37	G 3/8	-	-	G 3/8	38	185	10	80
12222103	DN 15 1/2**	78	51	46	37	G 1/2	-	-	G 1/2	40	220	10	80
12222703	DN 20 3/4	95	63	47	37	G 3/4	-	-	G 3/4	51	305	8	64



Fittings for copper pipe



Fittings for plastic pipe



Fittings for multilayer pipe



Fittings: chapter 7



Accessories: chapter 1.A

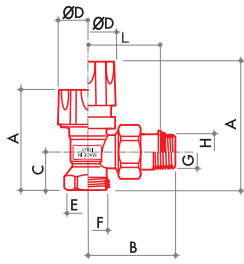

RS 2502

Angle radiator valve, thermostatically or electronically controlled, with manual control knob. Connection for iron pipe.



Fittings



CODE	SIZE	A	B	C	D	E	F	G	H	L			
12621700	DN 10 3/8	75	50	20	37	G 3/8	-	R 3/8	-	-	165	10	80
12622100*	DN 15 1/2**	78	53	23	37	G 1/2	-	R 1/2	-	-	201	10	80
12622700	DN 20 3/4	78	62	27	37	G 3/4	-	R 3/4	-	-	277	8	64

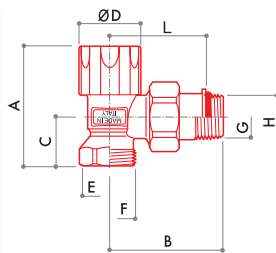

DS 22

Angle regulating lockshield. Connection for iron pipe.

Fittings



CODE	SIZE	A	B	C	D	E	F	G	H	L			
10061700	DN 10 3/8	53	50	20	30	G 3/8	-	R 3/8	-	-	132	10	80
10062100	DN 15 1/2**	57	54	23	30	G 1/2	-	R 1/2	-	-	170	10	80
10062700	DN 20 3/4	57	62	27	30	G 3/4	-	R 3/4	-	-	244	8	64

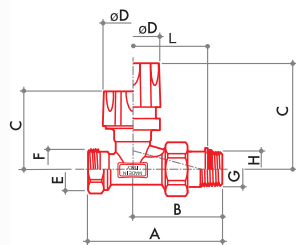

RD 2501

Straight radiator valve, thermostatically or electronically controlled, with manual control knob. Connection for iron pipe.

Fittings



CODE	SIZE	A	B	C	D	E	F	G	H	L			
12421700	DN 10 3/8	76	51	64	37	G 3/8	-	R 3/8	-	-	184	10	80
12422100	DN 15 1/2**	83	55	64	37	G 1/2	-	R 1/2	-	-	220	10	80
12422700	DN 20 3/4	97	65	65	37	G 3/4	-	R 3/4	-	-	309	8	64

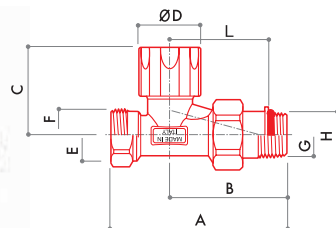

DD 21

Straight regulating lockshield. Connection for iron pipe.

Fittings



CODE	SIZE	A	B	C	D	E	F	G	H	L			
10261700	DN 10 3/8	76	51	41	30	G 3/8	-	R 3/8	-	-	153	10	80
10262100	DN 15 1/2**	83	55	42	30	G 1/2	-	R 1/2	-	-	187	10	80
10262700	DN 20 3/4	97	65	43	30	G 3/4	-	R 3/4	-	-	273	8	64

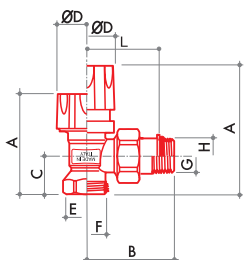

RS 2506

Angle radiator valve, thermostatically or electronically controlled, with manual control knob. Connection for iron pipe.



Fittings



** Only for the sizes indicated

CODE	SIZE	A	B	C	D	E	F	G	H	L			
12622117	DN 10 3/8	75	47	20	37	G 3/8	-	-	G 3/8	37	192	10	80
12622103*	DN 15 1/2**	78	49	23	37	G 1/2	-	-	G 1/2	39	224	10	80
12622703	DN 20 3/4	78	60	27	37	G 3/4	-	-	G 3/4	48	275	8	64

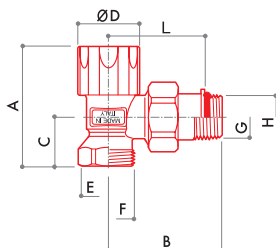

DS 26

Angle regulating lockshield. Connection for iron pipe.

Fittings



** Only for the sizes indicated

CODE	SIZE	A	B	C	D	E	F	G	H	L			
10062117	DN 10 3/8	53	47	20	30	G 3/8	-	-	G 3/8	37	138	10	80
10062103	DN 15 1/2**	57	50	23	30	G 1/2	-	-	G 1/2	39	174	10	80
10062703	DN 20 3/4	57	57	27	30	G 3/4	-	-	G 3/4	45	247	8	64

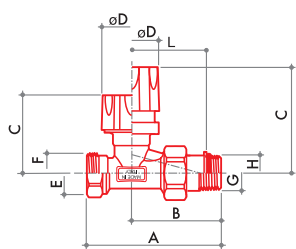

RD 2505

Straight radiator valve, thermostatically or electronically controlled, with manual control knob. Connection for iron pipe.

Fittings



** Only for the sizes indicated

CODE	SIZE	A	B	C	D	E	F	G	H	L			
12422117	DN 10 3/8	73	48	64	37	G 3/8	-	-	G 3/8	38	173	10	80
12422103	DN 15 1/2**	78	51	64	37	G 1/2	-	-	G 1/2	40	205	10	80
12422703	DN 20 3/4	95	63	65	37	G 3/4	-	-	G 3/4	51	290	8	64

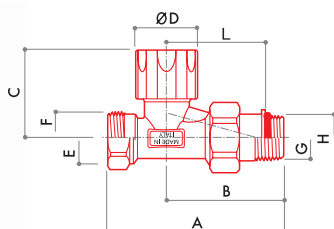

DD 25

Straight regulating lockshield. Connection for iron pipe.

Fittings



** Only for the sizes indicated

CODE	SIZE	A	B	C	D	E	F	G	H	L			
10262117	DN 10 3/8	73	48	41	30	G 3/8	-	-	G 3/8	38	159	10	80
10262103	DN 15 1/2**	78	51	42	30	G 1/2	-	-	G 1/2	40	191	10	80
10262703	DN 20 3/4	95	63	43	30	G 3/4	-	-	G 3/4	51	276	8	64

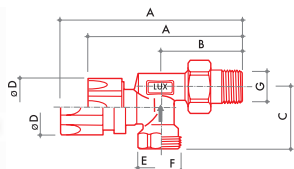

M 332

Reverse angle radiator valve, thermostatically or electronically controlled, with manual control knob. Connection for iron pipe.

Fittings



** Only for the sizes indicated

CODE	SIZE	A	B	C	D	E	F	G	H	L			
13222100	DN 15 1/2	116	52	40	35	G 1/2	-	R 1/2	-	-	228	10	80



Fittings for copper pipe



Fittings for plastic pipe



Fittings for multilayer pipe



Fittings: chapter 7



Accessories: chapter 1.A

CONNECTION FOR COPPER AND PLASTIC PIPE W24X19

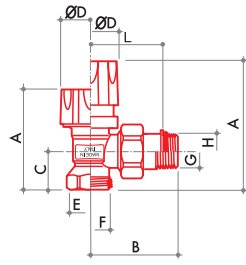

RS 212

Angle radiator valve, thermostatically or electronically controlled, with protection cap.
Connection for copper and plastic pipe.

Fittings



CODE	SIZE	A	B	C	D	E	F	G	H	L			
12121700*	DN 10 3/8	57	52	19	37	-	W24x19	R 3/8	-	-	158	10	80
12122100*	DN 15 1/2	59	54	22	37	-	W24x19	R 1/2	-	-	182	10	80

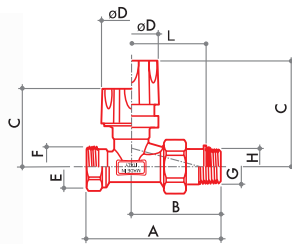

RD 211

Straight radiator valve, thermostatically or electronically controlled, with protection cap.
Connection for copper and plastic pipe.

Fittings



CODE	SIZE	A	B	C	D	E	F	G	H	L			
12321700	DN 10 3/8	76	51	46	37	-	W24x19	R 3/8	-	-	179	10	80
12322100	DN 15 1/2	81	55	46	37	-	W24x19	R 1/2	-	-	203	10	80

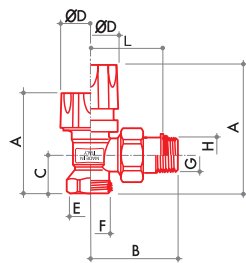

RS 209

Angle radiator valve, thermostatically or electronically controlled, with protection cap.
Connection for copper and plastic pipe.

Fittings



CODE	SIZE	A	B	C	D	E	F	G	H	L			
12122117*	DN 10 3/8	57	47	19	37	-	W24x19	-	G 3/8	37	164	10	80
12122103*	DN 15 1/2	60	49	22	37	-	W24x19	-	G 1/2	39	185	10	80

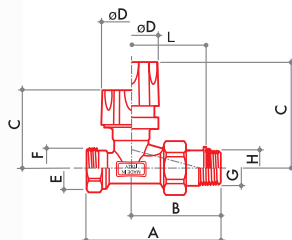

RD 208

Straight radiator valve, thermostatically or electronically controlled, with protection cap.
Connection for copper and plastic pipe.

Fittings



CODE	SIZE	A	B	C	D	E	F	G	H	L			
12322117	DN 10 3/8	73	48	46	37	-	W24x19	-	G 3/8	38	186	10	80
12322103	DN 15 1/2	78	51	46	37	-	W24x19	-	G 1/2	40	203	10	80

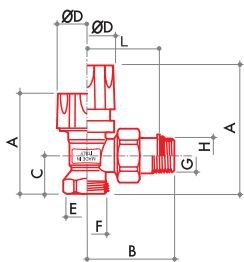

RS 2512

Angle radiator valve, thermostatically or electronically controlled, with manual control knob. Connection for copper and plastic pipe.



Fittings

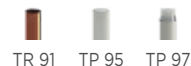

CODE	SIZE	A	B	C	D	E	F	G	H	L			
12721700*	DN 10 3/8	74	52	19	37	-	W24x19	R 3/8	-	-	166	10	80
12722100*	DN 15 1/2	77	54	22	37	-	W24x19	R 1/2	-	-	192	10	80

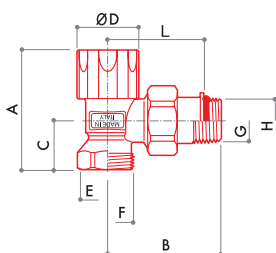

DS 32

Angle regulating lockshield. Connection for copper and plastic pipe.

Fittings



CODE	SIZE	A	B	C	D	E	F	G	H	L			
10161700	DN 10 3/8	52	50	19	30	-	W24x19	R 3/8	-	-	130	10	80
10162100	DN 15 1/2	56	54	22	30	-	W24x19	R 1/2	-	-	159	10	80

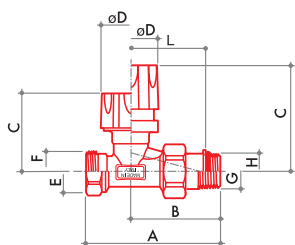

RD 2511

Straight radiator valve, thermostatically or electronically controlled, with manual control knob. Connection for copper and plastic pipe.

Fittings



CODE	SIZE	A	B	C	D	E	F	G	H	L			
12521700	DN 10 3/8	76	51	64	37	-	W24x19	R 3/8	-	-	185	10	80
12522100	DN 15 1/2	81	55	64	37	-	W24x19	R 1/2	-	-	207	10	80

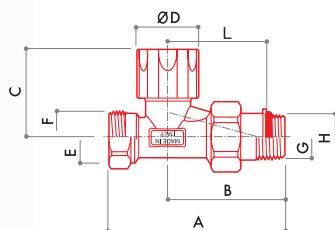

DD 31

Straight regulating lockshield. Connection for copper and plastic pipe.

Fittings



CODE	SIZE	A	B	C	D	E	F	G	H	L			
10361700	DN 10 3/8	76	51	41	30	-	W24x19	R 3/8	-	-	155	10	80
10362100	DN 15 1/2	82	55	42	30	-	W24x19	R 1/2	-	-	178	10	80



Fittings for copper pipe



Fittings for plastic pipe



Fittings for multilayer pipe



Fittings: chapter 7



Accessories: chapter 1.A

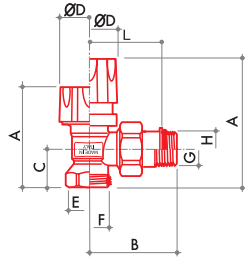

RS 2509

Angle radiator valve, thermostatically or electronically controlled, with manual control knob. Connection for copper and plastic pipe.



Fittings



CODE	SIZE	A	B	C	D	E	F	G	H	L			
12722117*	DN 10 3/8	74	47	19	37	-	W24x19	-	G 3/8	37	172	10	80
12722103*	DN 15 1/2	77	49	22	37	-	W24x19	-	G 1/2	39	193	10	80

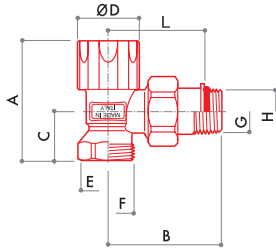

DS 39

Angle regulating lockshield. Connection for copper and plastic pipe.

Fittings



CODE	SIZE	A	B	C	D	E	F	G	H	L			
10162117	DN 10 3/8	52	47	19	30	-	W24x19	-	G 3/8	37	141	10	80
10162103	DN 15 1/2	56	49	22	30	-	W24x19	-	G 1/2	39	163	10	80

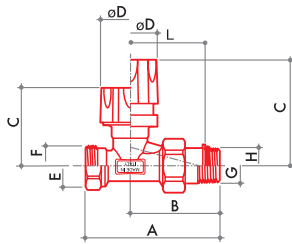

RD 2508

Straight radiator valve, thermostatically or electronically controlled, with manual control knob. Connection for copper and plastic pipe.

Fittings



CODE	SIZE	A	B	C	D	E	F	G	H	L			
12522117	DN 10 3/8	73	48	64	37	-	W24x19	-	G 3/8	38	194	10	80
12522103	DN 15 1/2	77	51	64	37	-	W24x19	-	G 1/2	40	211	10	80

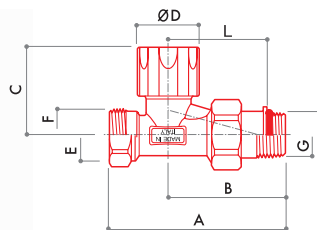

DD 38

Straight regulating lockshield. Connection for copper and plastic pipe.

Fittings



CODE	SIZE	A	B	C	D	E	F	G	H	L			
10362117	DN 10 3/8	73	48	41	30	-	W24x19	-	G 3/8	38	162	10	80
10362103	DN 15 1/2	77	51	42	30	-	W24x19	-	G 1/2	40	178	10	80

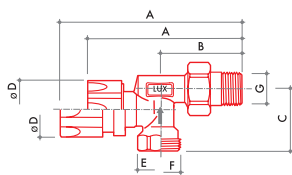

M 330

Reverse angle radiator valve, thermostatically or electronically controlled, with manual control knob. Connection for copper and plastic pipe.

Fittings



CODE	SIZE	A	B	C	D	E	F	G	H	L			
13122100	DN 15 1/2	116	52	39	35	-	W24x19	R 1/2	-	-	215	10	80

CONNECTION FOR COPPER AND PLASTIC PIPE G3/4 EUROKONUS

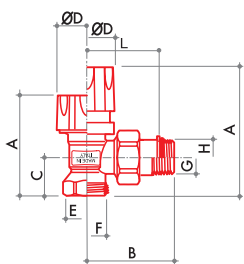

RS 212/A

Angle radiator valve, thermostatically or electronically controlled, with protection cap. Eurokonus connection.



Fittings



CODE	SIZE	A	B	C	D	E	F	G	H	L			
12122718*	DN 10 3/8	56	50	19	37	-	G 3/4 EK	R 3/8	-	-	157	10	80
12122721*	DN 15 1/2	59	54	22	37	-	G 3/4 EK	R 1/2	-	-	181	10	80

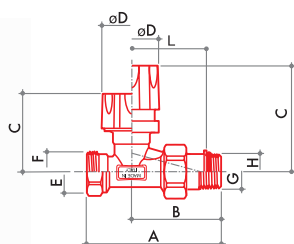

RD 211/A

Straight radiator valve, thermostatically or electronically controlled, with protection cap. Eurokonus connection.

Fittings



CODE	SIZE	A	B	C	D	E	F	G	H	L			
12322719	DN 10 3/8	77	52	46	37	-	G 3/4 EK	R 3/8	-	-	170	10	80
12322722	DN 15 1/2	81	55	46	37	-	G 3/4 EK	R 1/2	-	-	199	10	80

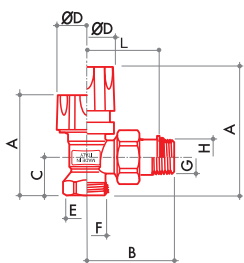

RS 209/A

Angle radiator valve, thermostatically or electronically controlled, with protection cap. Eurokonus connection.



Fittings



CODE	SIZE	A	B	C	D	E	F	G	H	L			
12122717*	DN 10 3/8	57	47	19	37	-	G 3/4 EK	-	G 3/8	37	163	10	80
12122703*	DN 15 1/2	60	49	22	37	-	G 3/4 EK	-	G 1/2	39	184	10	80

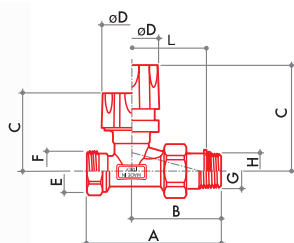

RD 208/A

Straight radiator valve, thermostatically or electronically controlled, with protection cap. Eurokonus connection.

Fittings

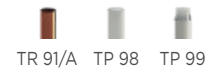

CODE	SIZE	A	B	C	D	E	F	G	H	L			
12322717	DN 10 3/8	73	48	46	37	-	G 3/4EK	-	G 3/8	38	182	10	80
12322703	DN 15 1/2	77	51	46	37	-	G 3/4EK	-	G 1/2	40	199	10	80



Fittings for copper pipe



Fittings for plastic pipe



Fittings for multilayer pipe



Fittings: chapter 7



Accessories: chapter 1.A

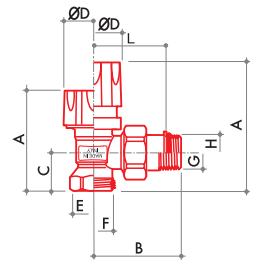

RS 2512/A

Angle radiator valve, thermostatically or electronically controlled, with manual control knob. Eurokonus connection.



Fittings



CODE	SIZE	A	B	C	D	E	F	G	H	L			
12722718*	DN 10 3/8	74	50	19	37	-	G 3/4 EK	R 3/8	-	-	163	10	80
12722721*	DN 15 1/2	77	54	22	37	-	G 3/4 EK	R 1/2	-	-	189	10	80

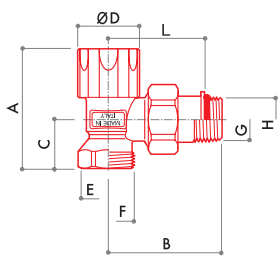

DS 32/A

Angle regulating lockshield. Connections eurokonus type.

Fittings

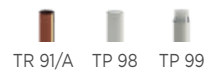

CODE	SIZE	A	B	C	D	E	F	G	H	L			
10162718	DN 10 3/8	52	50	19	30	-	G 3/4 EK	R 3/8	-	-	139	10	80
10162721	DN 15 1/2	56	54	22	30	-	G 3/4 EK	R 1/2	-	-	162	10	80

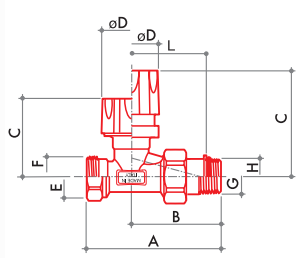

RD 2511/A

Straight radiator valve, thermostatically or electronically controlled, with manual control knob. Eurokonus connection.

Fittings



CODE	SIZE	A	B	C	D	E	F	G	H	L			
12522719	DN 10 3/8	77	52	64	37	-	G 3/4 EK	R 3/8	-	-	196	10	80
12522722	DN 15 1/2	81	55	64	37	-	G 3/4 EK	R 1/2	-	-	207	10	80

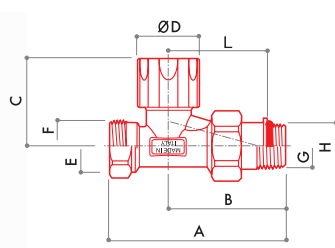

DD 31/A

Straight regulating lockshield. Connections eurokonus type.

Fittings



CODE	SIZE	A	B	C	D	E	F	G	H	L			
10362719	DN 10 3/8	76	51	41	30	-	G 3/4 EK	R 3/8	-	-	164	10	80
10362722	DN 15 1/2	82	55	42	30	-	G 3/4 EK	R 1/2	-	-	174	10	80

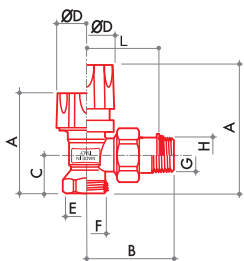

RS 2509/A

Angle radiator valve, thermostatically or electronically controlled, with manual control knob. Eurokonus connection.



Fittings



CODE	SIZE	A	B	C	D	E	F	G	H	L			
12722717*	DN 10 3/8	74	47	19	37	-	G 3/4EK	-	G 3/8	37	171	10	80
12722703*	DN 15 1/2	77	49	22	37	-	G 3/4EK	-	G 1/2	39	192	10	80

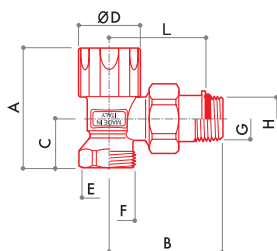

DS 39/A

Angle regulating lockshield. Connections eurokonus type.

Fittings



CODE	SIZE	A	B	C	D	E	F	G	H	L			
10162717	DN 10 3/8	52	47	19	30	-	G 3/4 EK	-	G 3/8	37	144	10	80
10162703	DN 15 1/2	56	49	22	30	-	G 3/4 EK	-	G 1/2	39	166	10	80

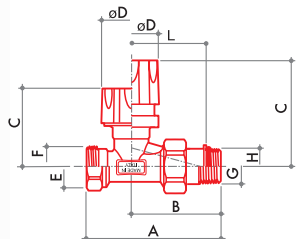

RD 2508/A

Straight radiator valve, thermostatically or electronically controlled, with manual control knob. Eurokonus connection.

Fittings



CODE	SIZE	A	B	C	D	E	F	G	H	L			
12522717	DN 10 3/8	73	48	64	37	-	G 3/4EK	-	G 3/8	38	190	10	80
12522703	DN 15 1/2	77	51	64	37	-	G 3/4EK	-	G 1/2	40	207	10	80

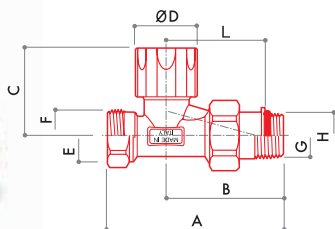

DD 38/A

Straight regulating lockshield. Connections eurokonus type.

Fittings



CODE	SIZE	A	B	C	D	E	F	G	H	L			
10362717	DN 10 3/8	73	48	41	30	-	G 3/4 EK	-	G 3/8	38	165	10	80
10362703	DN 15 1/2	77	51	42	30	-	G 3/4 EK	-	G 1/2	40	178	10	80

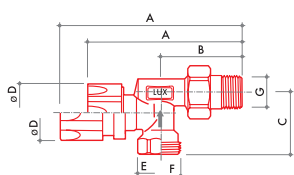

M 330/A

Reverse angle radiator valve, thermostatically or electronically controlled, with manual control knob. Eurokonus connection.

Fittings



CODE	SIZE	A	B	C	D	E	F	G	H	L			
13122721	DN 15 1/2	116	52	39	35	-	G 3/4 EK	R 1/2	-	-	217	10	80



Fittings for copper pipe



Fittings for plastic pipe



Fittings for multilayer pipe



Fittings: chapter 7



Accessories: chapter 1.A

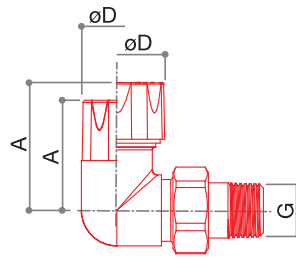

MD 321/A

Coaxial right radiator valve, thermostatically or electronically controlled, with protection cap. Eurokonus connection.

Fittings



CODE	SIZE	A	B	C	D	E	F	G	H	L			
13272722	DN 15 1/2	49	56	27	37	-	G 3/4 EK	R 1/2	-	-	287	10	80

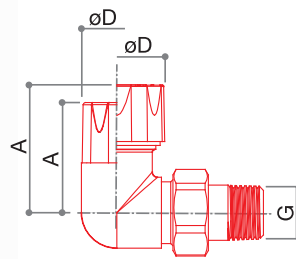

MS 331/A

Coaxial left regulating lockshield. Eurokonus connections.

Fittings



CODE	SIZE	A	B	C	D	E	F	G	H	L			
13252722	DN 15 1/2	42	56	27	30	-	G 3/4 EK	R 1/2	-	-	258	10	80

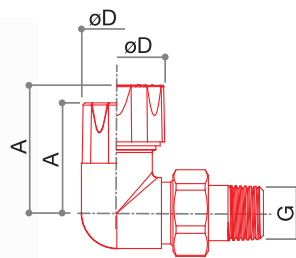

MS 321/A

Left coaxial radiator valve, thermostatically or electronically controlled, with protection cap. Eurokonus connection.

Fittings



CODE	SIZE	A	B	C	D	E	F	G	H	L			
13292722	DN 15 1/2	49	56	27	37	-	G 3/4 EK	R 1/2	-	-	287	10	80

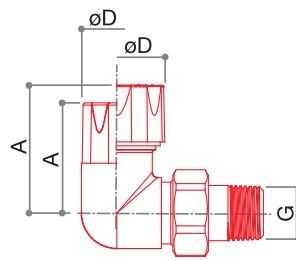

MD 331/A

Coaxial right regulating lockshield. Eurokonus connections.

Fittings



CODE	SIZE	A	B	C	D	E	F	G	H	L			
13232722	DN 15 1/2	42	56	27	30	-	G 3/4 EK	R 1/2	-	-	258	10	80

TT 3000

THERMOSTATIC HEAD



TECHNICAL DATA

VALVE CONNECTION

- Max temperature
120 °C
- Max pressure
10 bar
- Max differential pressure
0,6 bar
- Min. adjustment temperature (anti-freeze pos.)**
Ts min 6 °C
- Max regulation temperature (max position)**
Ts max 30 °C (5)
- Energy saving conditions**
20 °C

- Thermostatic element inalterability range**
-15 °C ÷ 60 °C
- Storage temperature**
-20 °C ÷ + 50 °C
- Hysteresis**
C 0,4 k
- Differential pressure influence**
D 0,5 k
- Water temperature influence**
W 0,25 k
- Response time**
Z 22 min.
- Control Accuracy**
CA 0,2 K.



Available with
chrome finish
(chapter 50th Series)



CONSTRUCTIVE FEATURES

Thermostatic heads consist of a sensor filled with a highly expandable element. This element, which may be incorporated in the adjustment knob or in the remote sensor, expands or contracts in proportion to room temperature changes, reacting even to the smallest variation. When the surrounding

temperature increases, the element expands and acts on the obturator with an axial thrust movement, thus controlling the valve action. The flow of the heating medium can be adjusted by opening and closing the valve.

TECHNICAL FEATURES IN COMBINATION WITH THERMOSTATIC HEAD TT 3000

POS	ITEM	Kv Δt 1 °C	Kv ΔT 1 °C	qmN (Kg/h)	qm max (Kg/h)	a
1	RS 202 DN 15 - RS 206 DN 15	0.07	0.07	23±65%	32	0.42
2	RS212 DN10 - RS212 DN15 RS209 DN10 - RS209 DN15	0.20	0.25	80±40%	100	0.36
3	RS212/A DN15 - RS209/A DN15	0.24	0.36	113±30%	155	0.46
4	RS2502 DN15 - RS2506 DN15 RS2512 DN10 - RS2512 DN15	0.24	0.37	116±20%	180	0.57
5	RS2509 DN10 - RS2509 DN15	0.24	0.40	128±20%	250	0.74
6	RS2512/A DN15 - RS2509/A DN15	0.32	0.52	165±10%	440	0.84

RANGE OF ADJUSTMENT

Thermostatic valves allow to make each room independent with a specific set temperature, thus enhancing comfort and actual energy saving, as prescribed by national and international regulations. Thermostatic heads can also maintain an anti-freeze temperature (position “❄️”), which is very useful in order to prevent frost damage when rooms are not being used. During summer it is instead recommended to set the heads to the maximum opening (position “5”).

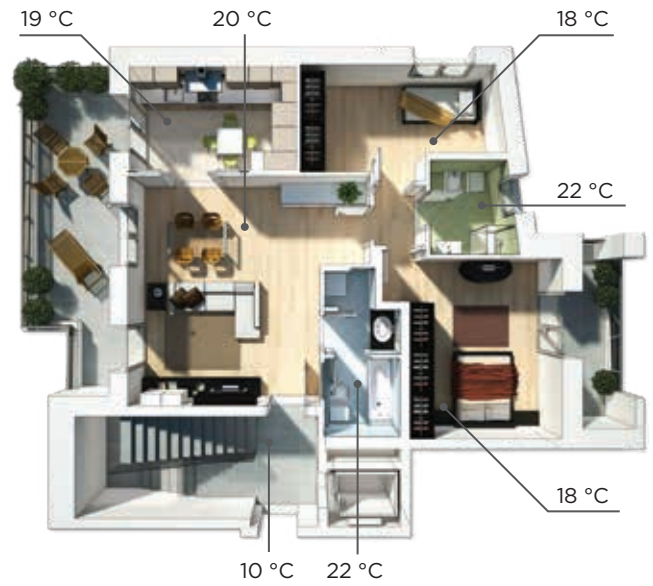
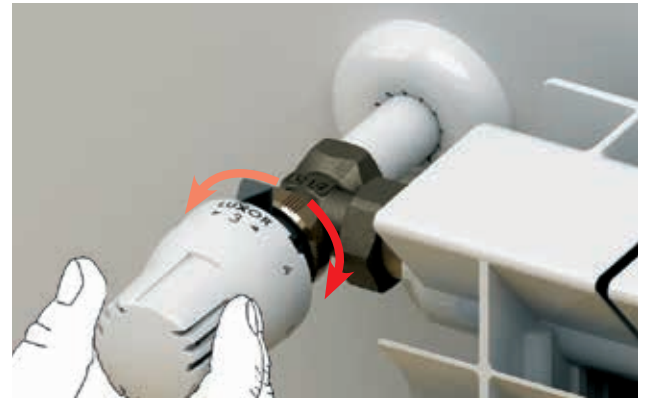
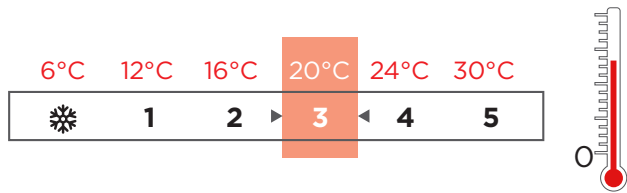

INSTRUCTIONS FOR USE

Before installing the thermostatic head, set the adjustment knob to “5”, so as to facilitate the following installation steps. Unscrew the RAL 9016 white ABS protection cap mounted on ThermoTekna thermostic valves. Tighten the brass collar of the thermostatic head to the valve body, then set the knob to the desired position.



LIMITING AND LOCKING TEMPERATURE



The head's temperature range can be limited or locked by using the provided fork pin.

To lock the temperature to “3”, turn the knob so that the indicator corresponds to the required position. The temperature can be locked by inserting the fork pin across the

spline placed diametrically opposite to the index (fig. 1). Insert the fork pin to the left of the spline to limit the temperature to values between “3” and “5” (fig. 2), to the right to set a temperature range between “3” and “❄️” (fig. 3).

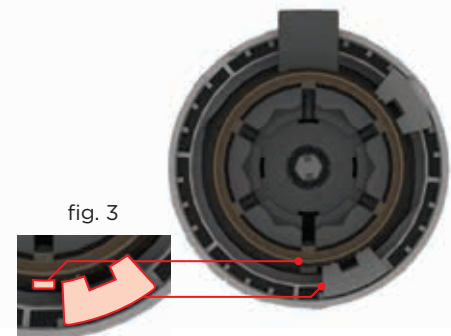
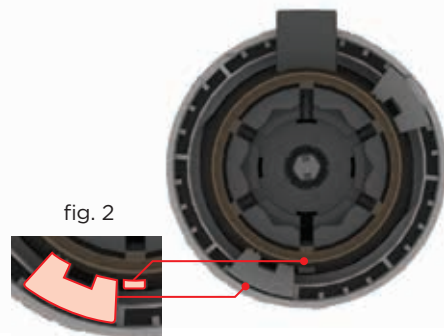
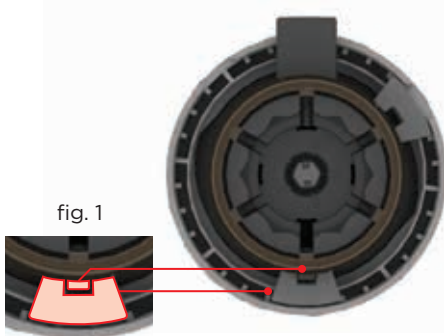

INSTALLATION WARNINGS



TT3000 thermostatic heads can be applied to all heating bodies unless in presence of barriers such as shelves, curtains or furniture, which may accumulate heat and therefore alter the measurement of room temperature. In this case, it is recommended to use **TT3002** thermostatic heads with remote sensor.

In systems where all heating bodies are controlled by thermostatic heads, it is advisable to install a bypass valve in order to avoid noise due to the excessive pressure difference which might arise inside thermostatic valves.

Thermostatic heads must be installed away from the heat streams surrounding the heating body (fig. 1) and direct sunlight (fig. 2).

Do not install thermostatic heads under shelves (fig. 3), in a recess (fig. 4), within the heat stream (fig. 5) or behind curtains (fig. 6).

These kinds of installation are not proper, as they may cause the head to measure temperature values which do not coincide with the actual room temperature.



Should the heating body be installed as in fig. 1, a number of issues may arise. The door could not be opened completely and, unless provided with a doorstop, it could hit and damage the head.

In cases like this, it is advisable to use a reverse radiator valve as shown in fig. 2.

THERMOSTATIC HEADS

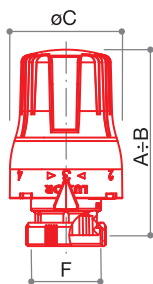

TT 3000

Thermostatic head with integrated control and sensor.



CODE	SIZE	A	B	C	D	E	F	G	H	L			
69100000	M30x1,5	75	80	46,5	-	-	M30x1,5	-	-	-	110	1	100

CODE	SIZE	A	B	C	D	E	F	G	H	L			
69100000BRA*	M30x1,5	75	80	46,5	-	-	M30x1,5	-	-	-	110	1	100

*With Braille numbers

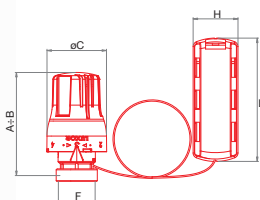

TT 3002

Thermostatic head with integrated control and remote sensor. Standard length of capillary 2 m.

CODE	SIZE	A	B	C	D	E	F	G	H	L			
69100020	M30x1,5	75	80	46,5	-	-	M30x1,5	-	35	96	156	1	32



BT 242

Tamper-and-theft-proof clip for TT 3000 and TT 3002.

CODE	SIZE			
69010402	-	14	5	160

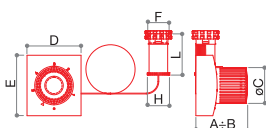

TT 2302

In-wall thermostatic head with control and remote sensor. Standard length of capillary 2 m.

CODE	SIZE	A	B	C	D	E	F	G	H	L			
69011005	M30x1,5	63	68	45	67	75	M30x1,5	-	28	51	220	1	30



The certification of the valves according to UNI EN 215 applies to the coupling valve+thermostatic head Luxor TT 3000. **Technical information are available on our website: www.luxor.it**

VALVES FLOW RATE CHART

ANGLE VALVES DN 10 - DN 15

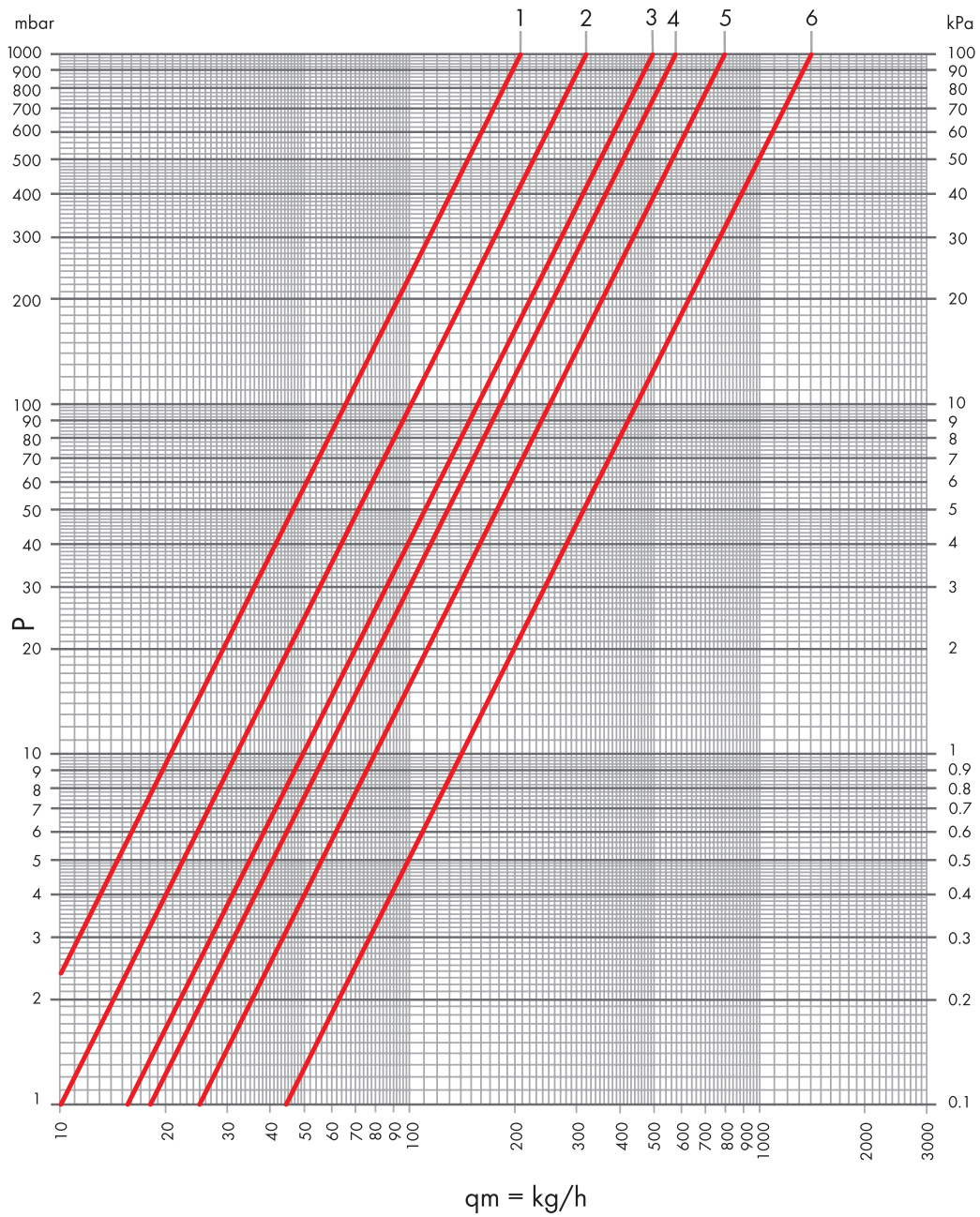

ITEM	Kv	Kv Δt 1 °C	Kv Δt 2 °C	POS
Angle DN 10 - DN 15	0.10	0.07	0.07	1
	0.32	0.20	0.25	2
	0.49	0.24	0.36	3
	0.57	0.24	0.37	4
	0.79	0.24	0.40	5
	1.39	0.32	0.55	6

VALVES FLOW RATE CHART

ANGLE VALVES DN 20

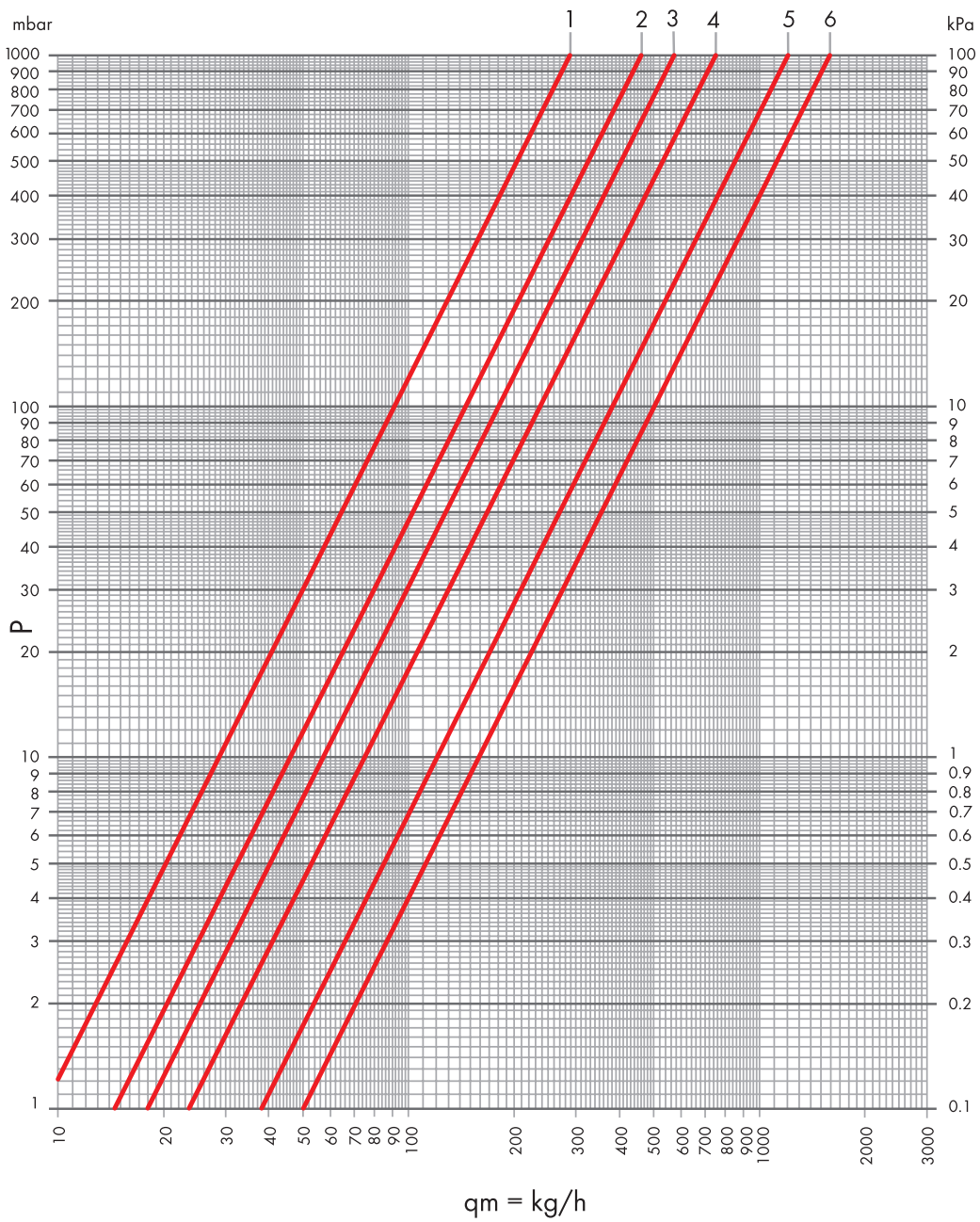

ITEM	Kv	Kv Δt 1 °C	Kv Δt 2 °C	POS
Angle DN 20	0.29	0.15	0.19	1
	0.49	0.20	0.25	2
	0.57	0.24	0.36	3
	0.75	0.26	0.41	4
	1.20	0.31	0.55	5
	1.58	0.32	0.56	6

VALVES FLOW RATE CHART

STRAIGHT VALVES

DN 10 - DN 15

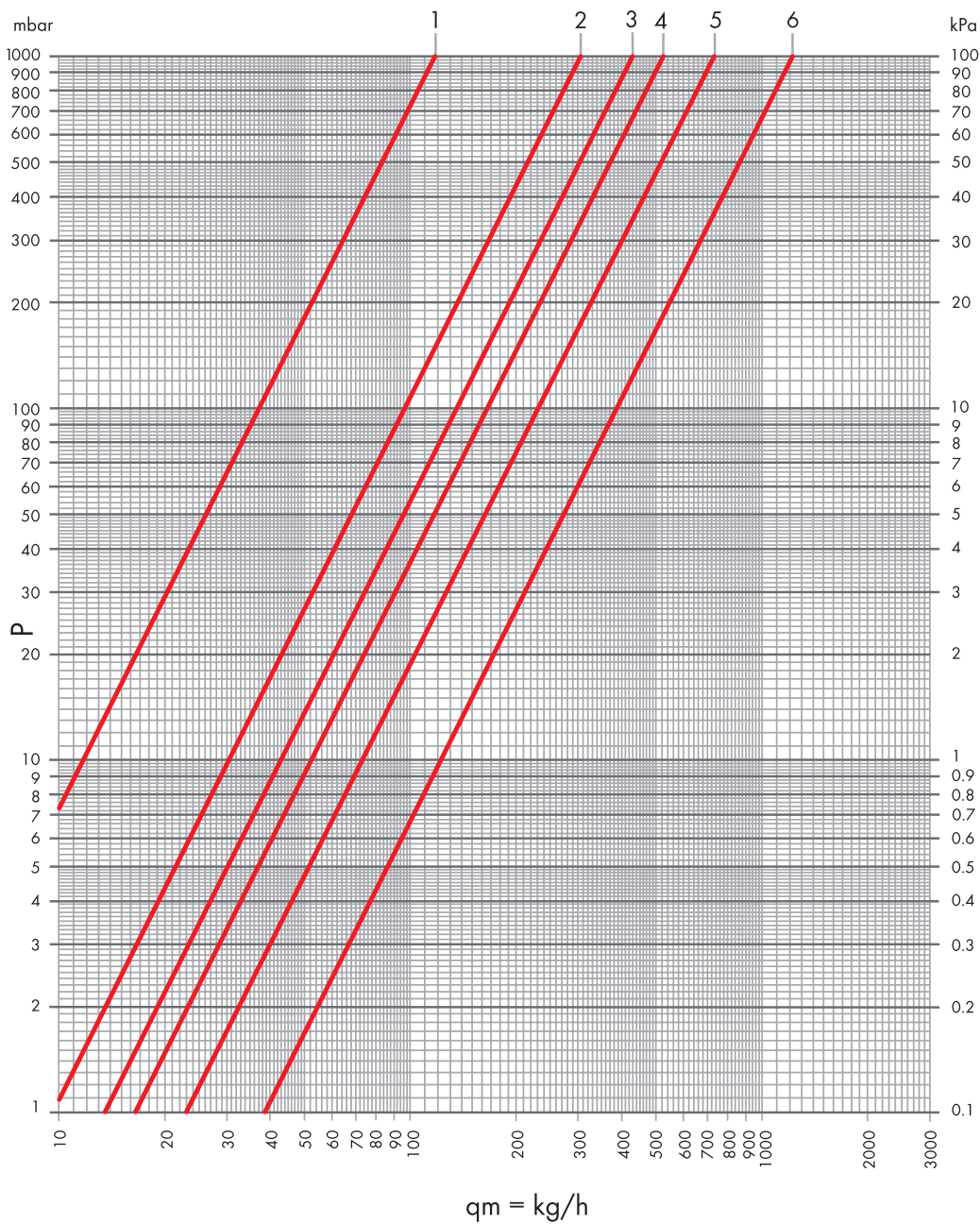

ITEM	Kv	Kv Δt 1 °C	Kv Δt 2 °C	POS
Straight DN 10 - DN 15	0.12	0.10	0.11	1
	0.30	0.20	0.25	2
	0.43	0.24	0.36	3
	0.52	0.24	0.37	4
	0.72	0.24	0.40	5
	1.21	0.29	0.49	6

VALVES FLOW RATE CHART

STRAIGHT VALVES

DN 20

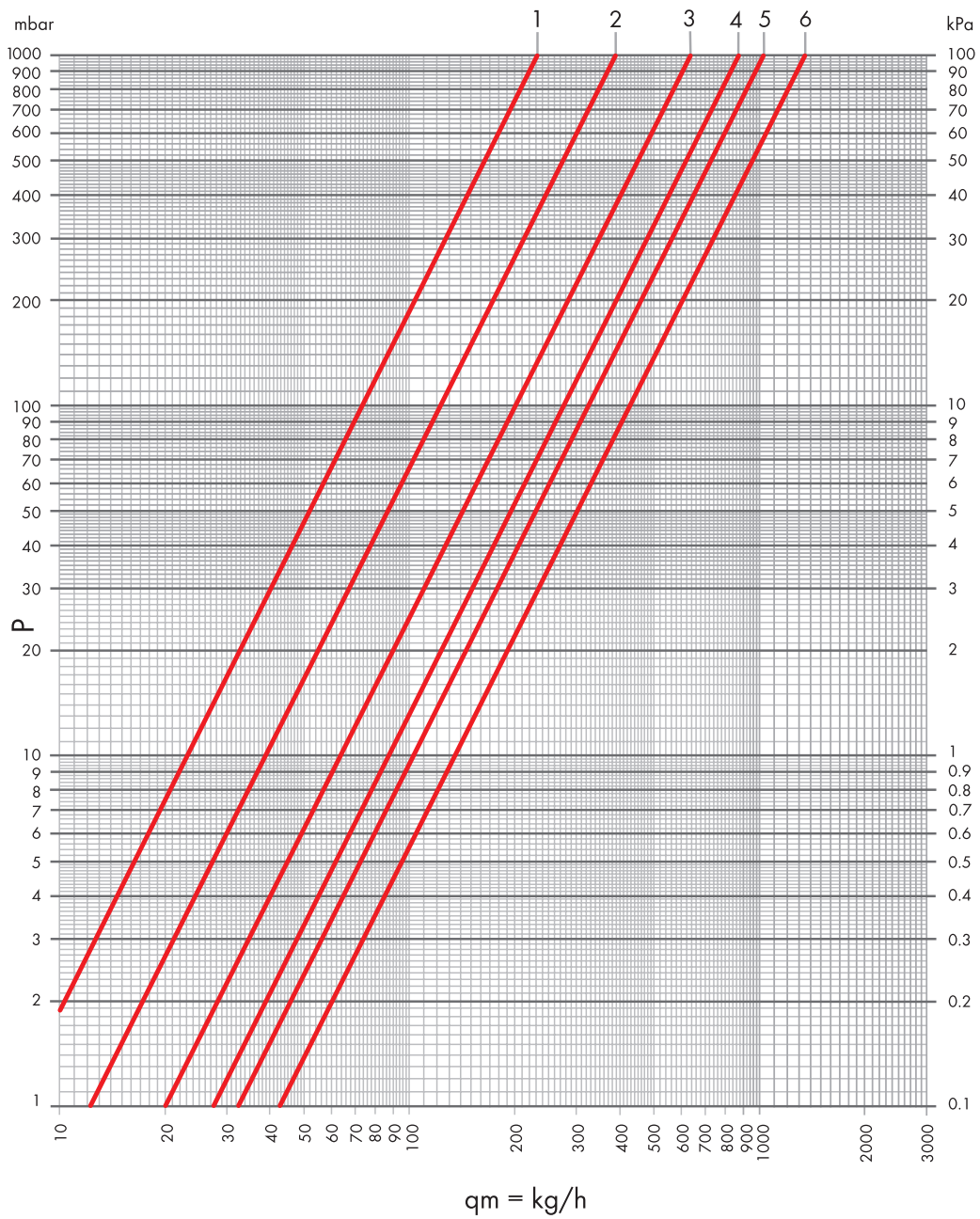

ITEM	Kv	Kv Δt 1 °C	Kv Δt 2 °C	POS
Straight DN 20	0.23	0.16	0.19	1
	0.39	0.22	0.25	2
	0.63	0.25	0.36	3
	0.87	0.29	0.41	4
	1.02	0.30	0.50	5
	1.34	0.31	0.52	6

LOCKSHIELD FLOW RATE CHART

ANGLE LOCKSHIELD

DN 10 3/8

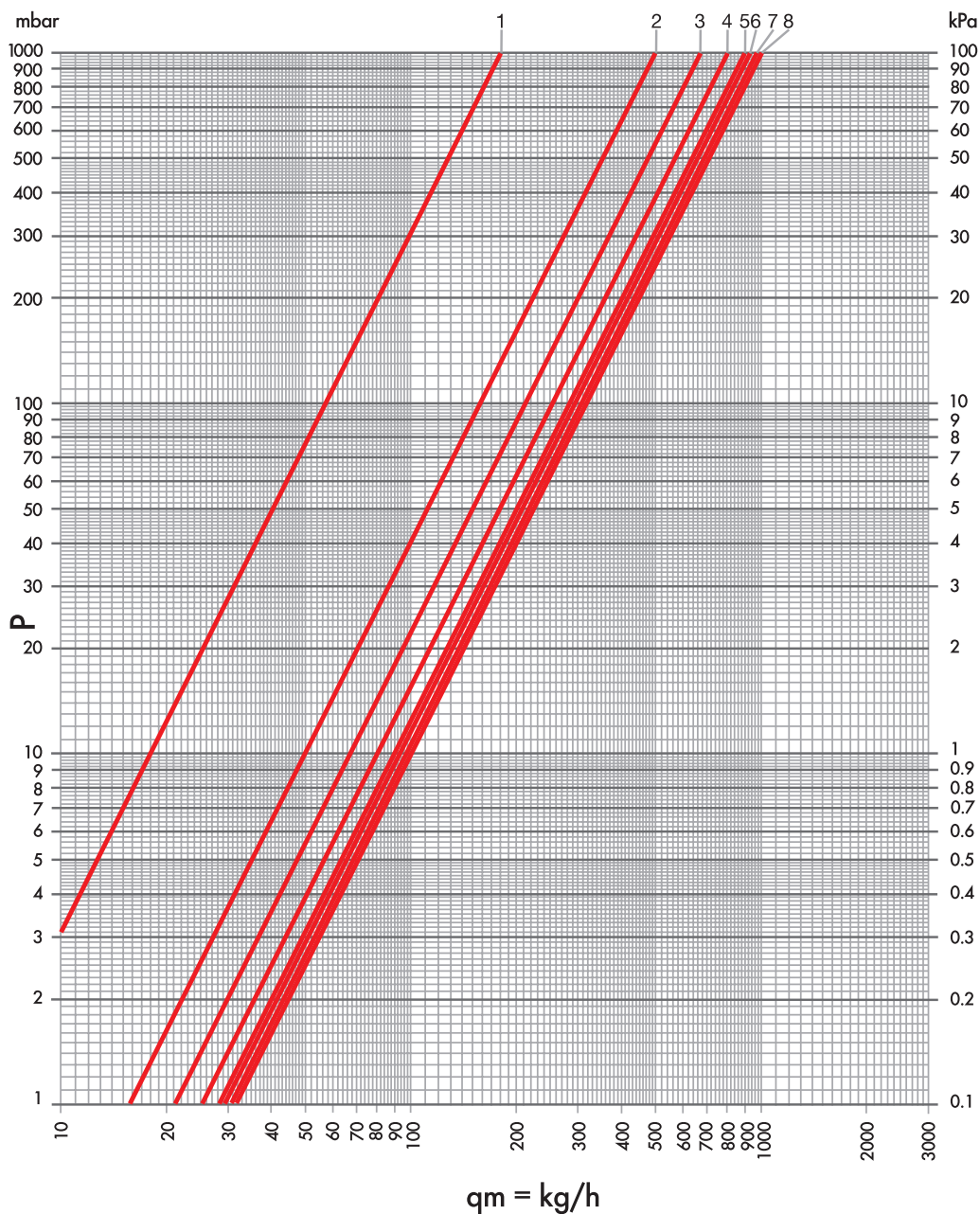

ITEM	TURNS N°	Kvs	POS
DS 22 DS 26 DS 32 DS 39 DS 32/A DS 39/A	1	0.18	1
	1+1/2	0.50	2
	2	0.67	3
	2+1/2	0.80	4
	3	0.90	5
	3+1/2	0.93	6
	4	0.97	7
	all open	1.00	8

LOCKSHIELD FLOW RATE CHART

ANGLE LOCKSHIELD

DN 15 1/2

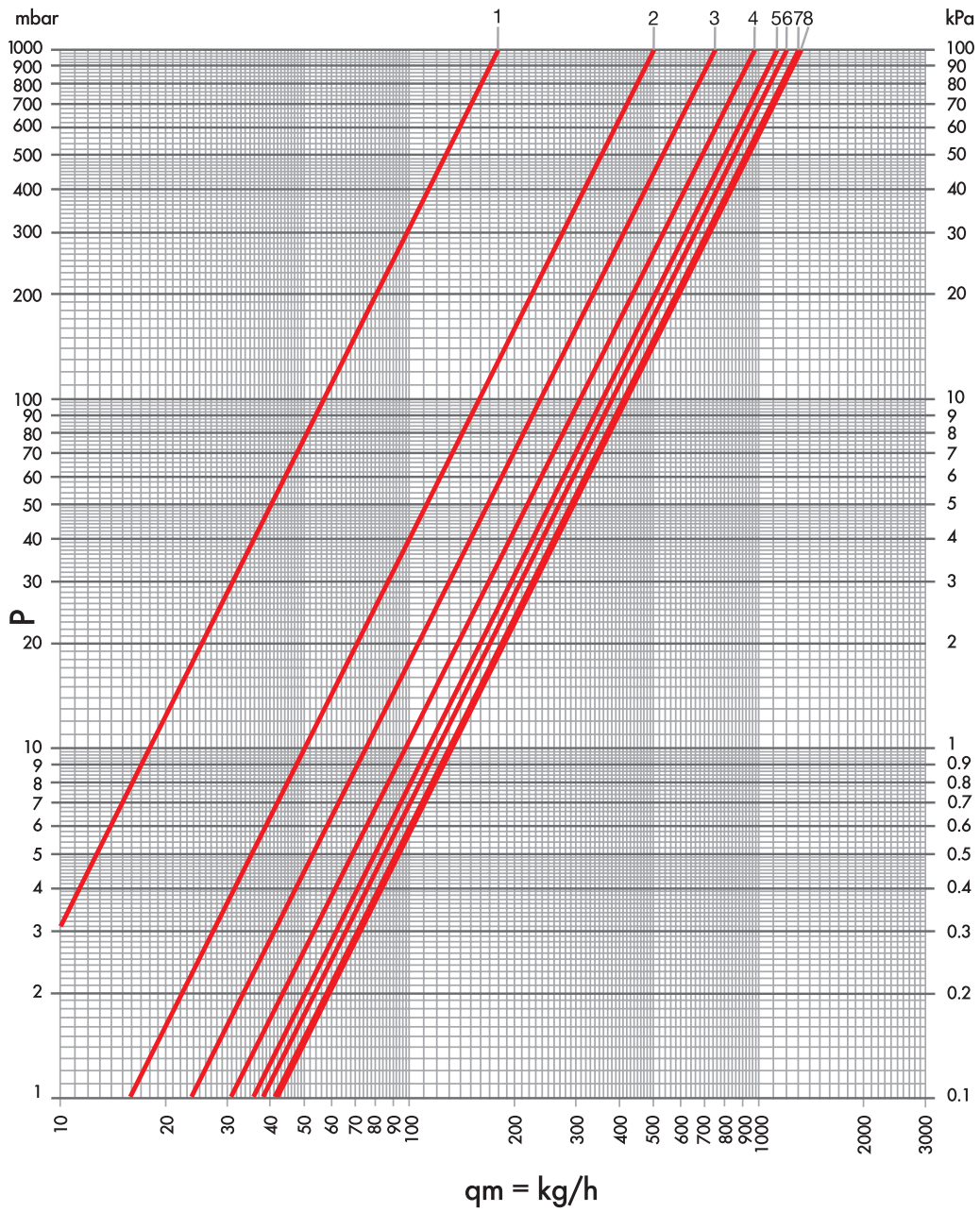

ITEM	TURNS N°	Kvs	POS
DS 22 DS 26 DS 32 DS 39 DS 32/A DS 39/A	1	0.18	1
	1+1/2	0.50	2
	2	0.75	3
	2+1/2	0.97	4
	3	1.12	5
	3+1/2	1.20	6
	4	1.30	7
	all open	1.31	8

LOCKSHIELD FLOW RATE CHART

ANGLE LOCKSHIELD

DN 20 3/4

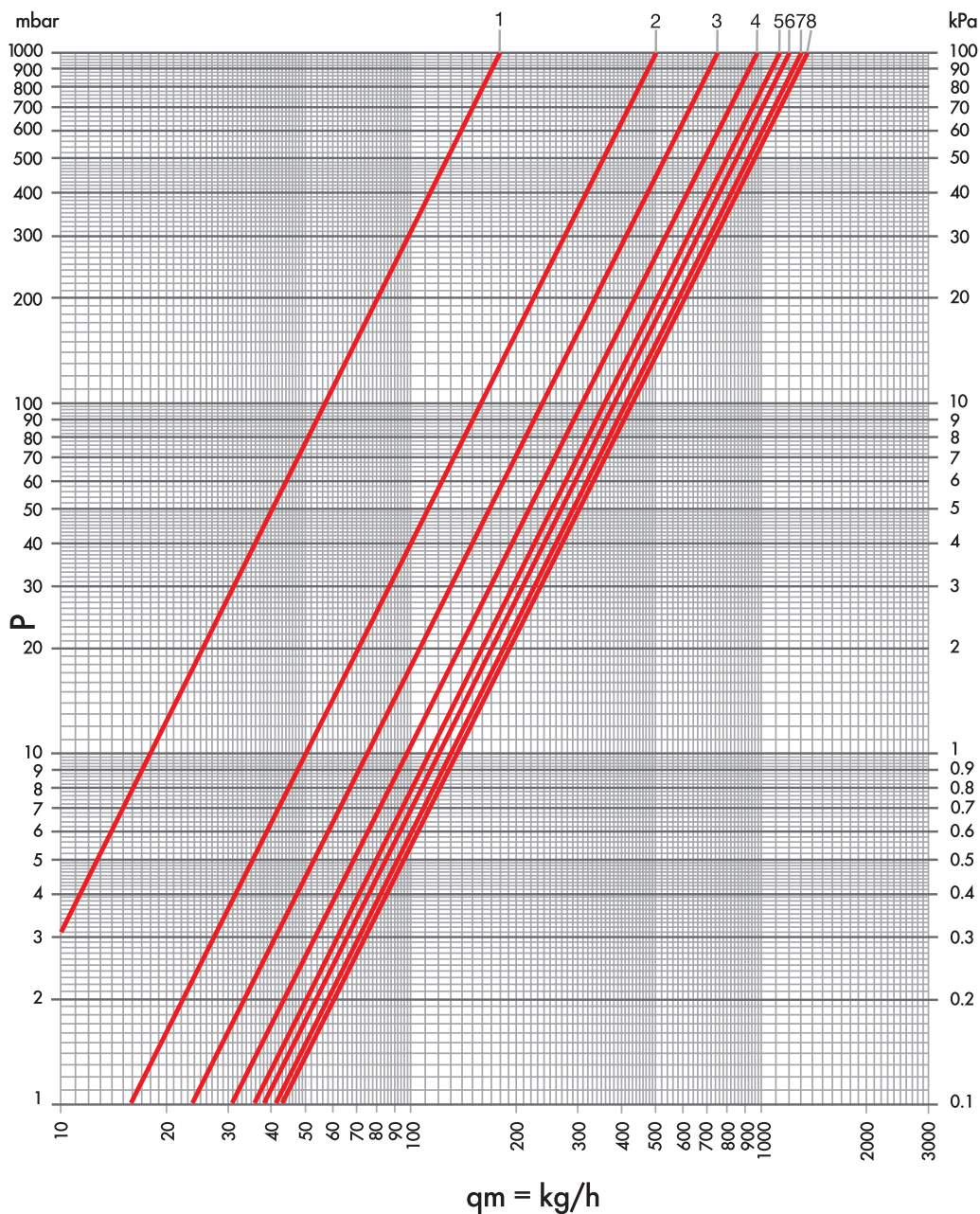

ITEM	TURNS N°	Kvs	POS
DS 22 DS 26 DS 32 DS 39 DS 32/A DS 39/A	1	0.18	1
	1+1/2	0.50	2
	2	0.75	3
	2+1/2	0.97	4
	3	1.12	5
	3+1/2	1.20	6
	4	1.30	7
	all open	1.34	8

LOCKSHIELD FLOW RATE CHART

STRAIGHT LOCKSHIELD

DN 10 3/8

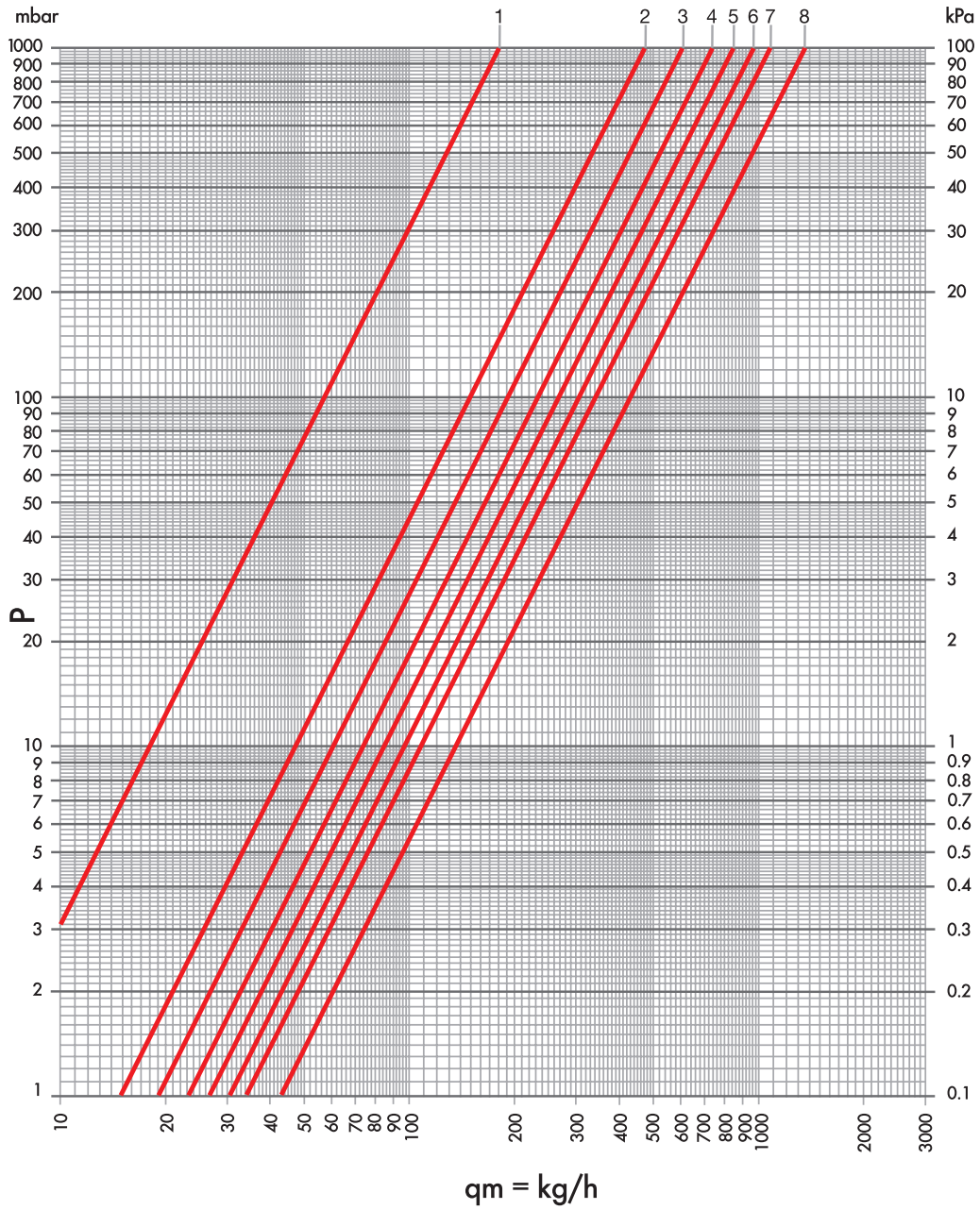

ITEM	TURNS N°	Kvs	POS
DD 21 DD 25 DD 31 DD 38 DD 31/A DD 38/A	1	0.18	1
	1+1/2	0.47	2
	2	0.60	3
	2+1/2	0.73	4
	3	0.84	5
	3+1/2	0.95	6
	4	1.07	7
	all open	1.34	8

LOCKSHIELD FLOW RATE CHART

STRAIGHT LOCKSHIELD

DN 15 1/2

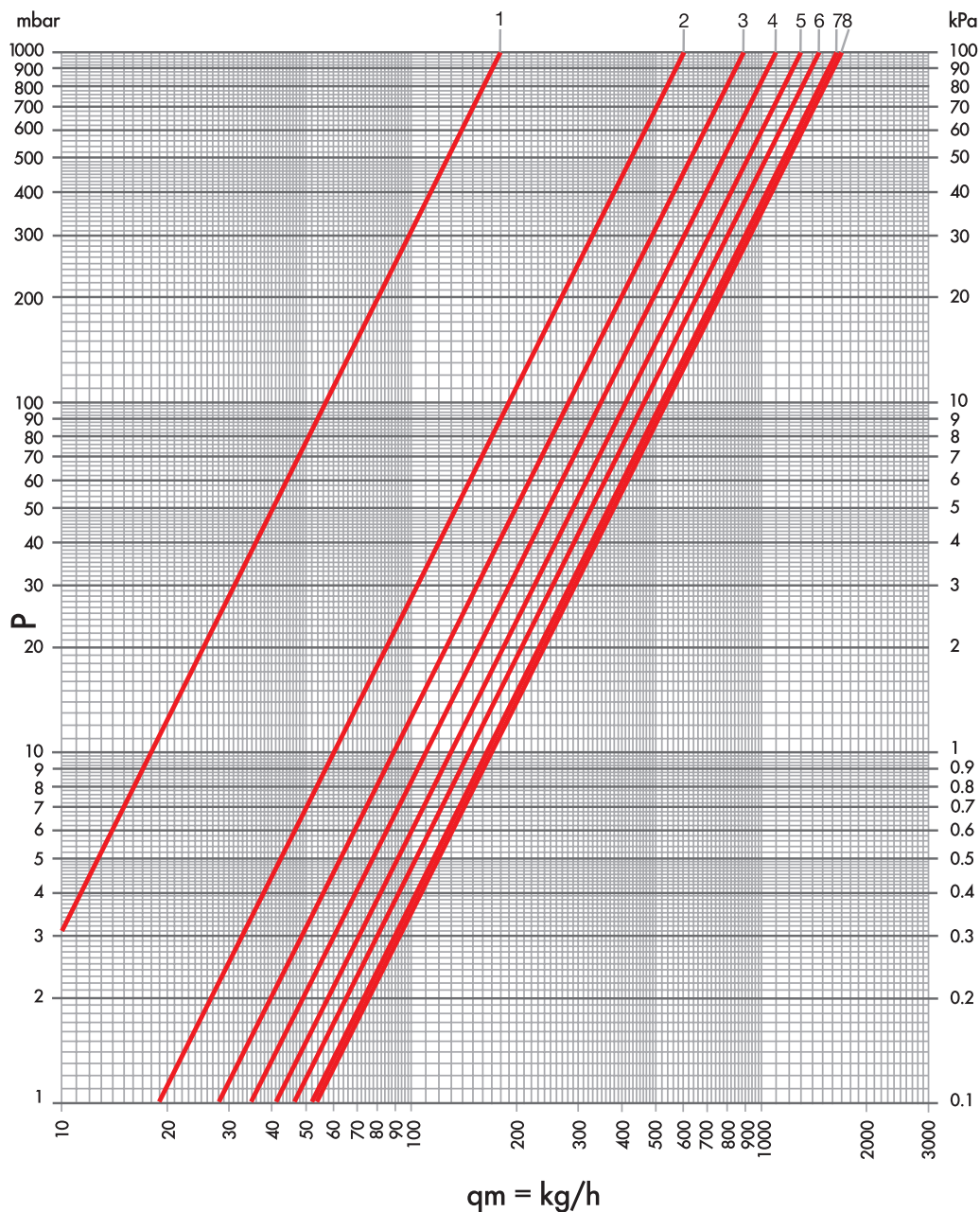

ITEM	TURNS N°	Kvs	POS
DD 21 DD 25 DD 31 DD 38 DD 31/A DD 38/A	1	0.18	1
	1+1/2	0.60	2
	2	0.89	3
	2+1/2	1.10	4
	3	1.30	5
	3+1/2	1.46	6
	4	1.63	7
	all open	1.70	8

LOCKSHIELD FLOW RATE CHART

STRAIGHT LOCKSHIELD

DN 20 3/4

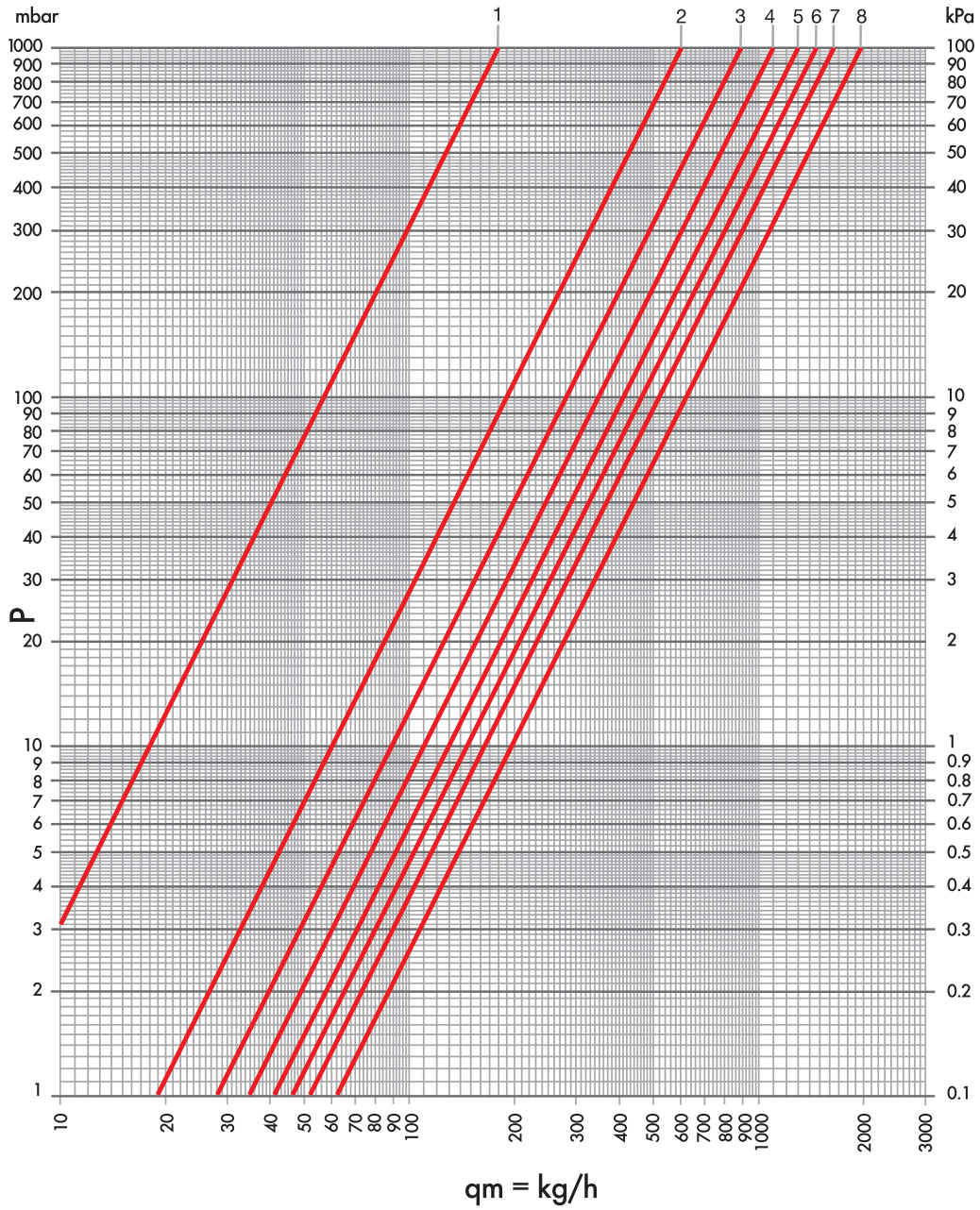

ITEM	TURNS N°	Kvs	POS
DD 21 DD 25 DD 31 DD 38 DD 31/A DD 38/A	1	0.18	1
	1+1/2	0.60	2
	2	0.89	3
	2+1/2	1.10	4
	3	1.30	5
	3+1/2	1.46	6
	4	1.63	7
	all open	1.96	8

GENERAL CONDITIONS OF SALE

1 PREMISES - 1.1 The present conditions of sale apply to all supplies of Luxor Spa Products (hereafter "Luxor"). Any general conditions, and in particular the conditions of purchase of the Buyer (hereafter "Customer"), unless expressly accepted in writing by Luxor, shall not bind the latter nor exempt the Customer from the application of the present General Conditions (hereafter GSC)

2. ORDERS - 2.1 The Purchase Orders (referred to as 'Orders') are an irrevocable purchase proposal. By placing an Order, customers fully accept the present General Conditions of Sale.

2.2 Orders are considered accepted only after Luxor confirms them in writing. The Order confirmation and/or Invoice issued by Luxor will be considered as confirmation.

2.3 Any changes to the Order requested by the Customer after the sending of the Order Confirmation will only be valid and enforceable after written acceptance by Luxor. Cancellation or modification of Orders without the prior written consent of Luxor, will give Luxor the right to act to obtain reimbursement of the costs incurred, without prejudice to the right to compensation for greater damages.

3 PRICES - 3.1 Luxor products will be invoiced based on the current price list at the time the order is accepted. Prices do not include VAT or any other taxes.

3.2 Prices listed in sales catalogues/lists are merely indicative and may be subject to change due to production cost increases. In such cases, Luxor will inform the purchaser of the price increase and provide the reasons.

4 DELIVERY TERMS - 4.1 The supplies in each individual Order will be delivered within the stated terms in the Order Confirmation.

4.2 Luxor will not be held responsible for delays in delivery that are not caused by Luxor, such as delays by third parties, including suppliers and sub-suppliers, shippers, and causes of force majeure that result in total or partial inactivity of the plants. In the cases mentioned above, the Customer cannot refuse delivery of the goods, even if it is only partial, nor can they use a delay in delivery as a reason to terminate the contract or claim damages.

5 SHIPMENTS - 5.1 The products will be delivered to the 'Assigned Port' (Incoterms 2020 EXW), with transport costs and risks borne by the buyer, unless otherwise agreed.

5.2 Even in the case of agreed delivery in "Free Port" (Incoterms 2020 DDP) with costs borne by Luxor, the goods will still travel at the buyer's risk. Regardless of the delivery terms agreed upon by the parties, the risks will pass to the buyer at the latest with delivery to the first carrier.

5.3 The transfer of ownership of the goods is suspended until the full price has been paid, but this does not affect the transfer of risk to the purchaser.

5.4 If special packaging is required, an additional charge as indicated in the price list or order confirmation will be added to the invoice.

6 PAYMENTS - 6.1 Payments are due as per the terms and manner specified in the order confirmation and/or invoice.

6.2 Unless otherwise expressly agreed, payments must be made to the bank details mentioned in the sales invoice. For payments made from abroad via bank transfer, the OUR option must be selected to ensure that Luxor receives the net amount on the invoice after deducting bank charges and expenses. Luxor does not authorize any third parties, including agents and representatives, to collect money on its behalf.

6.3 The Customer is not permitted to suspend or delay payments, even in the event of claims or complaints of defects, and must adhere to the agreed terms.

6.4 In case of payment interruption or suspension, the Customer will be considered in default. Luxor reserves the right to charge expenses and interest as per Art. 5 and 6 of D.Lgs n. 192/2012, without prejudice to the right to terminate the contract. Delayed payment may also result in Luxor excluding the guarantee for the entire period of delay.

6.5 If the Customer fails to adhere to the agreed payment terms, or interrupts or suspends payment, Luxor reserves the right to suspend any ongoing supplies and/or make the execution of the current order conditional on the payment of the outstanding debt. Luxor may also withdraw from any further contracts with the Customer and cancel any previously granted favourable conditions, such as discounts or free gifts.

6.6 The Customer is not permitted to offset any claims they may have against Luxor with debts they owe to Luxor, unless formally authorised by Luxor

7 EXPRESS TERMINATION CLAUSE - 7.1 Luxor may terminate the contract immediately if the Customer is undergoing bankruptcy or liquidation proceedings, as well as in the event that the Customer is subject to execution proceedings and/or protests and the economic conditions suggest the purchaser is insolvent.

8 WARRANTY - 8.1 Luxor guarantees the conformity of the products supplied, free from defects that could make them unsuitable for their intended use. The guarantee may be invoked if the defect is due to

manufacturing errors or defects in raw materials that are the responsibility of Luxor.

8.2 Unless otherwise expressly agreed, the guarantee lasts for one (1) year from the date of delivery. The Customer must make a written complaint within eight (8) days from delivery in the case of apparent defects, or, in the case of hidden defects, from the time of discovery and in any event not later than twelve (12) months from delivery.

8.3 In the event of non-conforming products, Luxor may, at its discretion, provide the Buyer with replacement products of the same type and quantity free of charge ex works, after verifying the returned products. Any return must always be previously agreed and authorised by Luxor. The goods in question must be returned 'carriage paid' along with a note explaining the reason for the return within 30 days of Luxor's approval. Failure to do so will result in the authorization becoming invalid.

8.4 If Luxor does not recognize the defective products upon verification, it will invoice those sent as replacements. If Luxor does not recognize the defective products upon verification, they will invoice the replacements. If Luxor is unable to replace defective products, they may issue a credit note to the customer for the value of the defective products. This does not imply any responsibility on Luxor for direct, indirect, or consequential damages resulting from or connected to the defects or faults of the products.

8.5 It is important to note that this guarantee does not cover instances where the product has been installed, used or maintained in a manner that is contrary to the instructions and warnings provided in the installation, use, and maintenance manuals that were included with the product. Additionally, any installation or repair work should only be carried out by qualified personnel.

8.6 The guarantee will not apply if the Purchaser breaches their contractual obligations.

8.7 This warranty is the only warranty and replaces any other written, oral or implied warranties. By accepting these General Terms and Conditions, the Purchaser expressly waives any right of recourse arising from the sale and/or installation of the Products to a non-professional consumer.

9. RESERVATION OF PROPERTY 9.1 The sale of Luxor S.p. A's Products is carried out under reservation of ownership. Therefore the products will remain the property of Luxor S.p.A. until the full payment of the price by the buyer.

10 TRANSFER OF THE CONTRACT 10.1 It is forbidden to transfer the Contract and/or any interest, right and obligation connected to it to third parties without specific written approval by Luxor.

11 PRIVACY - 11.1 The Customer confirms that they have read the information regarding the processing of their personal data, as required by Articles 13 and 14 of Regulation (EU) 2016/679 (GDPR) as amended. The information can be found at <https://luxor.it/privacy-policy>. By accepting these GTC, the Customer consents to the processing of their personal data.

11.2 Luxor will process the personal data provided by the Customer, including through external parties, to fulfil legal obligations and carry out administrative and commercial tasks related to the contractual relationship.

12 APPLICABLE LAW AND COURT OF JURISDICTION - 12.1 Contract is governed by Italian law. Anything not expressly governed by these GVCs shall be governed by the rules on sale provided for in articles 1470 et seq. of the Italian Civil Code.

12.2 The Parties expressly exclude the application of the Vienna Convention on Contracts for the International Sale of Goods. Any disputes related to the Contract, including those regarding its validity, interpretation, execution, and termination, must be referred exclusively to the Court of Brescia.

12.3 Luxor reserves the right to take legal action at the competent court of the Customer's location to recover any outstanding debts. The local law will apply in this case.

13 FINAL CLAUSES - 13.1 The possible nullity and/or ineffectiveness of one or more provisions of these GTC shall not affect the validity of the Contract as a whole.

13.2 Any amendment to the Contract shall be valid only if made in writing and signed by authorised representatives of both Parties.

The customer acknowledges that they are not a 'consumer' and therefore the provisions of law relating to relations between entrepreneurs and consumers do not apply. The customer declares that they have paid particular attention to the following clauses: Introduction (1.1), Orders (2.1-2.3), Prices (3.2), Delivery Terms (4.1-4.2), Shipping (5.1-5.3), and 6. The following sections require approval: Payments (6.2 - 6.3 - 6.4 - 6.5 - 6.6); 7 Express Termination Clause (7.1); 8 Warranty (8.1 - 8.2 - 8.3 - 8.4 - 8.5 - 8.6 - 8.7); 9. Retention of Title (9.1); 10. Applicable Law and Jurisdiction (12.1 - 12.2 - 12.3); 13 Final Clauses (13.1 - 13.2), and they are to be specifically approved.

These general terms and conditions are published on LUXOR's website (<https://luxor.it/>) where they may be consulted, thereby taking full and proper cognisance thereof, pursuant to and for the purposes of Articles 1341 and 1342 of the Civil Code.